

Design and Fabrication of a Low Cost 3- Axis Mini-Computer Numerical Control Milling Machine

(Paper ID: CFP/1684/2020)

Author: Musonda Christopher

Dept. of Information and Communications Technology,
School of Engineering
Information and Communications University,
Lusaka Zambia.

Advisor: Moses Kaleji

Dept. of Information and Communications Technology,
School of Engineering,
Information and Communications University,
Lusaka Zambia.

ABSTRACT

Numerical control is such a useful concept that can control a machine with numeric values and codes. That is what is called a CNC machine, used in machining and automation industries. The commercial CNCs are bulky and so much expensive. As such, small scale industries cannot afford such machines. It is for this reason that this project was carried out to design a low cost 3- axis mini-CNC machine. It works with the simultaneous interpretation of software and hardware. The three-axis motion is controlled by Arduino Uno board with TB6560 stepper motor driver. The Arduino works here as an open source burner which burns the microcontroller with given hex codes. TB6560, basically receives the signals from the Arduino board and delivers the power to the stepper motors. Here GRBL software is used to convert G-codes of a specific design to the Arduino compatible code. In this paper we tried to build a very affordable CNC machine. Here we fabricated a 3 axis CNC router with completely automatic functions and tried to make it conversable to 3D printer. Nowadays with a digital control it has become more and more useful to use such machine tools with a coded software. This paper will present the design and fabrication of 3-axis milling machine computer numerically-controlled (CNC) machine which comprise the use of Arduino micro controller to produce pulse-width modulation (PWM) outputs in order to run the stepper motors that will be used in this work. A milling 3-axis CNC is previously used precisely surfaced designed for snapping of wood,

plastic sheet and thin sheet of metal alloy by using a rotating drill bit which its accuracy is much lesser than using a lesser cutter technique this machine tool is portable and it's controlled by computer (PC). Design and Fabrication of CNC with precision Stepper motors that contacted with the lead screw moment along 3 -axis. CNC machines are widely used in production fields since they produce similar parts in a minimum time, at higher speed and with possibly minimum error. A control system is designed, implemented and tested to control the operation of a laboratory CNC milling machine having three axes that are moved by using a stepper motor attached to each axis. The control system includes two parts, hardware part and software part, the hardware part uses a PC (works as controller) connected to the CNC machine through its parallel port by using designed interface circuit. The software part includes the algorithms needed to control the CNC. The sample that needs to be machined is drawn by using one of the design software like AUTOCAD or 3D MAX and is saved in file format (DXF), then that file is fed to the CNC machine controller by the CNC operator, so that part will be machined by the CNC machine. The CNC controller using developed algorithms that reads the DXF file feeds to the machine, extracts (line, circle or arc) shapes from the file and generates commands to move the CNC machine axes so that these shapes can be machined.

Keywords— CNC machine axes

1.0 Introduction

Computer Numerical Control (CNC) is one in which the functions and motions of a machine tool are controlled by means of a prepared computer program containing coded alphanumeric data. CNC can control the motions of the work piece, the input parameters such as feed, depth of cut, speed, and the functions such as turning spindle on/off. CNC machines can be divided into two groups: turning machines and milling machines. A turning machine is generally made up of a device that spins a work piece at high speed and a tool (sharp edge) that shaves off the undesired material from the work piece (where the tool is moved back and forth and in and out until the desired form is achieved). On the other hand, a milling machine is a machine that has a spindle (a device similar to a router) with a special tool that spins and cuts in various directions and moves in three different directions along the x, y, and z axes. The Computer Numerical Control (CNC) machining is a process used in the manufacturing sector that involves the use of computers to control machine tools as explained earlier on. Under CNC machining, machine tools function through numerical control. A computer program is customized for an object and the machines are programmed with language called G-code that essentially controls all features like feed rate, coordination, axis motions, location and speed. Required code is generated by manually or automatically by CAM software and forms a file which is loaded into CNC. The machines electronic system reads the dimensions and drives the motors and movement created. Mini CNCs are much smaller in size and affordable. With much smaller space CNCs can be used by normal people for domestic issues. In this project a mini CNC was developed to make it more portable and up gradable to 3D Printer for smaller issues with much less power. it is possible to use the tools of smaller dimension to machine materials like wood, aluminum and plastic materials.

1.2 Background

CNC stands for Computer Numerical Control and

has been around since the early 1950's in the United States, it was mostly used by the US Air Force for metalworking machine tool builders. Before this, it was called NC, for Numerical Control. It was basically meant for controlling movement. In the early 1970's computers were introduced to these controls, hence the name changes to Computer Numerical Control. It was a major advance in the ability of machines to faithfully reproduce complex part machining steps more accurately without human intervention or variability. CNC machine uses a stream of digital information (code) from a computer to move motors and other positioning systems in order to guide a spindle over raw material. Historically, you would not actually need a computer to create forms with a turning machine or a milling machine. Adding a computer to the mix allows you to design a product on a computer first and then specify how the machine should cut this product. To design the product is to produce a computer aided design (CAD) file. Then you specify how the machine should cut the product, and the result of that step is a computer-aided manufacturing (CAM) file (or G-Code file, or .NC file—there are many names for this type of file). This CAM file remembers all of the operations that the milling machine must follow to cut out the parts for the product. The computer tells the CNC machine how to build the part by interpreting the CAM file into signals that the CNC machine can understand. A CNC machine uses mathematics and coordinate systems to understand and process information about what to move, to where, and how fast. Most CNC machines are able to move in three controlled directions at once. These directions are called axes. The axes are given simple names such as X, Y and Z (based on the Cartesian coordinate system). The X axis is always the longest distance a machine or a part of a machine must travel. X may be the movement from front to back, Y the movement from left to right, and the Z is almost always vertical movement (normally the spindle's positioning movement up and down). A CNC

machine must be able to communicate with itself to operate. A computer numeric control unit sends position commands to motors. The motors must talk back to the control that; indeed, they have acted correctly to move the machine a given distance. The ability of CNC machines to move in three (or more) directions at once allows them to create almost any desired pattern or shape. All of this processing happens very fast. While people in most walks of life have never heard of this term, CNC has touched almost every form of manufacturing process in one way or another. At present, most CNC machines are tied into a network of computers and receive operating and tooling instructions via a software file containing the ".NC" extension. Today Modern CNC machines are also capable of running overnight or for several days without human supervision.

1.3 Justification Mini CNCs are much smaller in size and affordable. With much smaller storage space, CNCs can be used by normal people for domestic issues. This project of the DIY 3D printer machine was produced locally with the view to empower local manufacturers to produce parts that could be of relevance to the consumer. At the same time, parts such as the frame and others were locally made and other electronic components were imported making the machine cheaper compared to the imported complete assembled machines. With CNC, operators do not have to interact directly in the metalworking processes and it significantly reduces risks at workplace.

3 1.4 Significance The significances of this project are that; 1. CNC machines can be used continuously 24 hours a day, 365 days a year and only need to be switched off for occasional maintenance. 2. CNC machines are programmed with a design which can then be manufactured hundreds or even thousands of times. Each manufactured product will be exactly the same. 3. Less skilled/trained people can operate CNCs unlike manual lathes / milling machines etc. which need skilled engineers. 4. CNC machines can be updated by improving the software used to drive the machines 5. Training in the use of CNCs is

available through the use of _virtual software '. This is software that allows the operator to practice using the CNC machine on the screen of a computer. The software is similar to a computer game. 6. CNC machines can be programmed by advanced design software such as Pro/DESKTOP®, enabling the manufacture of products that cannot be made by manual machines, even those used by skilled designers / engineers. 7. Modern design software allows the designer to simulate the manufacture of his/her idea. There is no need to make a prototype or a model. This saves time and money. 8. One person can supervise many CNC machines once they are programmed, they can usually be left to work by themselves. Sometimes only the cutting tools need replacing occasionally. 9. A skilled engineer can make the same component many times. However, if each component is carefully studied, each one will vary slightly. A CNC machine will manufacture each component as an exact match.

1.2 Problem statement

The continuous quest for modernization and industrialization has brought a great challenge upon the third world countries such as Zambia. These countries have to keep on importing production machinery whose spares cannot be obtained locally but from outside. This problem has been compounded by these countries' lack of funds to acquire machinery that could produce the much-needed spares. However, the high cost of initial investment of Computer Numeric Control (CNC) machines is a huge obstacle to many companies. It is, therefore, imperative that avenues of adapting these machines to perform a variety of operations than what they were initially designed for are sought and thereby make the investment much more cost effective. A cobalt refinery plant at Chambishi Metals Pic running at normal capacity consumes about one collimator in every three to four weeks. The cost of replacement of each collimator is approximately US\$3800 from Mitutoyo and Foyer

in America. (Anon., 2015) 4 Chambishi Metals Pic notes that it is spending thousands of dollars in importing the component and is looking for means to have local manufacturers to produce it locally since this would be cheaper and readily available. However, local companies have so far failed to achieve the required tolerances using conventional machining and have very little or no capacity in ordering CNC machine tools. The collimator assembly is a water-cooled frontal electrode, used on the plasma arc torch. This torch is used in the reheating of the alloy prior to atomizing. A collimator is an assembly made up of two separate components whose metallurgical composition is 90 to 99 percent copper. In order to accommodate plasma gas flow, process thermodynamics and to prevent coolant leakages, collimator components are normally produced by precision machining, a process that is best performed on CNC lathe machine tools. It is for this reason that it was identified as a test piece for production. (Anon., 2015) 1.6 Main Objective The main objective of this project is to design and fabricate a low cost 3-axis CNC milling machine that would manufacture industrial components, easily operational, flexible and easy to interface and further promote rapid prototyping. 1.7 Specific Objectives The following were the specific objectives for the project: 1. To design and fabricate the CNC three axes (3 axis) machine component and assemble as a complete CNC milling machine using solid works software. 2. To design a low cost, easily operable, flexible and easy to interface 3. To design a CNC machine with low power consumption 4. To design a portable three axes(3-axis) CNC machine 1.8 Limitations The following are the limitations to the 3 axis CNC milling machine; 1. CNC 3-axis machines are more expensive than manually operated machines, although costs are slowly coming down with time. 2. Depending on their age and sophistication, generally, 3-axis CNC machines can be limited to the capabilities of their control and drive systems. Most CNC controllers only understand straight line

movements and circular arcs. 3. The speed at which the machine controller can receive and process the incoming data, transmit commands to the drive system, and monitor the machine 's speed and position is critical. As such requires high levels of skill for its maintenance. 5 4. Rotary axis movements can be considered like linear movements, just degrees instead of distance. To create arc movements or linear movements that are at an angle to the principal axes, two or more axes must be interpolated (move precisely in a synchronized manner) together. Linear and rotary axes can also interpolate simultaneously. In the case of five axis machines, all five must be perfectly synchronized – no easy task. 5. Fewer workers are required to operate CNC machines compared to manually operated machines. Investment in CNC machines can lead to unemployment.

2: LITERATURE REVIEW

2.1 Introduction In this chapter, a review of previous research project that are related to this project will be discussed. This kind of survey was held as one of the tools to have some hands-on ideas on how this project works. It is based on other achievement and also to formulate the advantages of proposed solution. This may help in problem solving skills and options required for design and develop of portable CNC Milling machine purposed. 2.2 Review of the literature Before CNC machining was invented, all metalworking fabrication processes were completed with NC (Numerical Controlled) machines. The concept of was introduced in 1967 but the first CNC machines were introduced in 1976. Since then the popularity of CNC grew very significant and it was recognized as the industry standard in 1989. Today, almost all metalworking fabrication processes can be completed with CNC machines. Actually, there are many CNC variations for all metalworking equipment, such as grinders, turret punches, routers, milling machines, drills, lathes, EDMs, and high-

powered cutting devices. The main advantage is to improve safety, productivity, efficiency, and accuracy in metalworking fabrication. With CNC, operators do not have to interact directly in the metalworking processes and it significantly reduces risks at workplace. They can be operated continuously for 24 hours a day and 7 days a week. The machines only need to be turned off for regular maintenance. The reliability of these machines makes most companies to continue operating the machines during weekend, even without any human supervision. The machines are usually equipped with additional system that can contact off-site operator when an error occurs. When an error occurs, the process stops automatically.

2.2.1.3 Milling Machine Considerations

In general, milling machines are categorized into horizontal and vertical machine configurations, as well as differentiated based on the number of axes of motion. In vertical milling machines, the machine spindle is vertically oriented, while in horizontal milling machines the spindle is horizontally oriented. Horizontal machines also employ arbors for additional support and stability during the milling process, and have support capabilities for multiple cutting tools, such as in gang milling and straddle milling. Controls for both vertical and horizontal milling machine are dependent on the type of machine employed. For example, some machines can raise and lower the spindle and laterally move the worktable, while other machines have stationary spindles and worktables which move both horizontally, vertically, and rotationally. When deciding between vertical and horizontal milling machines, manufacturers and job shops must consider the requirements of the milling application, such as the number of surfaces requiring milling and the size and shape of the part. For example, heavier work pieces are better suited for 7 horizontal milling operations, while die sinking applications are better suited for vertical milling operations. Ancillary equipment that modifies vertical or horizontal machines to support

the opposing process is also available. Most CNC milling machines are available with 3 to 5 axes—typically providing performance along the XYZ axes and, if applicable, around rotational axes. The X-axis and Y-axis designate horizontal movement (side-to-side and forward-and-back, respectively, on a flat plane), while the Z-axis represents vertical movement (up-and-down) and the W-axis represents diagonal movement across a vertical plane. In basic CNC milling machines, horizontal movement is possible in two axes (XY), while newer models allow for the additional axes of motion, such as 3, 4, and 5-axis CNC machines. Table 2.1, below, outlines some of the characteristics of milling machines categorized by the number of axes of motion

Number of axes	Characteristics
1) Three (3-axes)	<ol style="list-style-type: none">1) Capable of managing most machining needs2) Capable of producing the same products as machines with more axes3) Suitable for automatic or interactive operation, cutting sharp edges, drilling holes, milling slots, etc.4) Simplest machine setup.5) Only requires one workstation.6) Higher knowledge requirements for operators.7) Lower levels of efficiency and quality
2) Four (4-axes)	<ol style="list-style-type: none">1) Capable of operating on materials ranging from aluminum and composite board to foam, PCB, and wood2) Suitable for advertising design, art creating, medical equipment creating, technology research, hobby prototype building, and industrial applications3) Greater functionality than 3-axis machines4) Higher levels of precision and accuracy than 3-axis machines5) More complex machine setup 3-axis machines6) More expensive than 3-axis machines

3) Five (5-axes)	<ol style="list-style-type: none"> 1) Multiple axes configurations available (e.g., 4+1, 3+2, or 5). 2) Suitable for aerospace, architectural, medical, military, oil and gas, and artistic and functional applications 3) Greatest functionality and capabilities. 4) Depending on configuration, faster operation than 3-axis and 4-axis machines. 5) Highest levels of quality and precision (A) 6) Depending on configuration, slower operation than 3-axis and 4-axis machines. 7) More expensive than 3-axis and 4-axis machines.
------------------	--

Table 2. 1 Characteristics of milling machines by axes of motion

2.2.1 3-Axis CNC Milling Operations NC milling is a machining process suitable for producing high accuracy, high tolerance parts in prototype, one-off, and small to medium production runs. While parts are typically produced with tolerances ranging between +/- 0.001 in. to +/- 0.005 in., some milling machines can achieve tolerances of up to and greater than +/- 0.0005 in. The versatility of the milling process allows it to be used in a wide range of industries and for a variety of part features and designs, including slots, chamfers, threads, and pockets. The most common CNC milling operations include; 1) Face milling. 2) Plain milling. 3) Angular milling. 4) Form milling. 5) End milling.

2.2.1.1 Face Milling Face milling refers to milling operations in which the cutting tool's axis of rotation is perpendicular to the surface of the work piece. The process employs face milling cutters which have teeth both on the periphery and tool face, with the peripheral teeth primarily being used for cutting and the face teeth being used for finishing applications. Generally, face milling is used to create flat surfaces and contours on the finished piece and is capable of producing higher quality finishes than other milling processes. Both vertical and horizontal milling machines support this process. Types of face milling include end milling and side milling, which use end milling cutters and side milling cutters, respectively. (Anon., 2016)

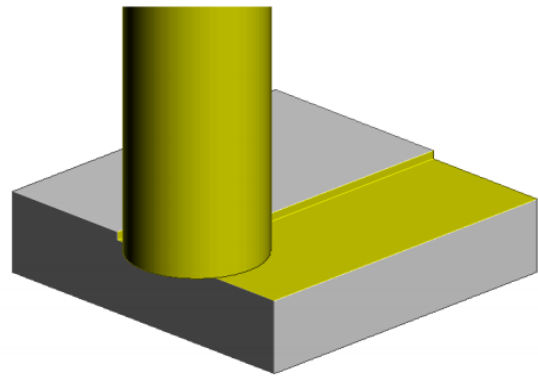

Figure 2. 1; face milling
Source: (Anon., 2017)

2.2.1.2 Plain Milling Plain milling, also known as surface or slab milling, refers to milling operations in which the cutting tool's axis of rotation is parallel to the surface of the work piece. The process employs plain milling cutters which have teeth on the periphery that perform the cutting operation. Depending on the specifications of the milling application, such as the depth of the cut and the size of the work piece, both narrow and wide cutters are used. Narrow cutters allow for deeper cuts, while wider cutters are used for cutting larger surface areas. If a plain milling application requires the removal of a large amount of material from the work piece, the operator first employs a coarse-toothed cutter, slow cutting speeds, and fast feed rates to produce the custom-designed part's approximate geometry. Then, the operator introduces a finer toothed cutter, faster cutting speeds, and slower feed rates to produce the details of the finished part. (Anon., 2016).

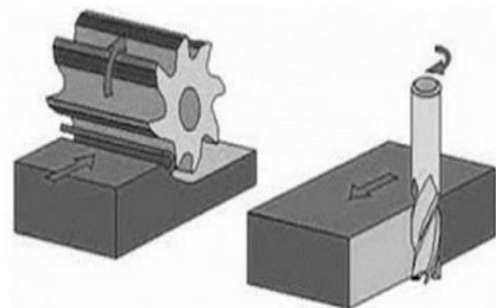

Figure 2.2: Plain Milling
Source: (Anon., 2018)

2.2.1.3 Angular Milling. Angular milling, also known as angle milling, refers to milling operations in which the cutting tool's axis of rotation is at an angle relative to the surface of the work piece. The process employs single-angle milling cutters—angled based on the particular design being machined—to produce angular features, such as chamfers, serrations, and grooves. One common application of angular milling is the production of dovetails, which employs 45°, 50°, 55°, or 60° dovetail cutters based on the design of the dovetail. (Anon., 2016).

2.2.1.4 Form Milling Form milling refers to milling operations involving irregular surfaces, contours, and outlines, such as parts with curved and flat surfaces, or completely curved surfaces. The process employs formed milling cutters or fly cutters specialized for the particular application, such as convex, concave, and corner rounding cutters. Some of the common applications of form milling include producing hemispherical and semi-circular cavities, beads, and contours, as well as intricate designs and complex parts with a single machine setup. (Anon., 2019)

2.2.1.5 End milling. In this process the cutter removes the material from the ends or sides of the work piece as shown below;

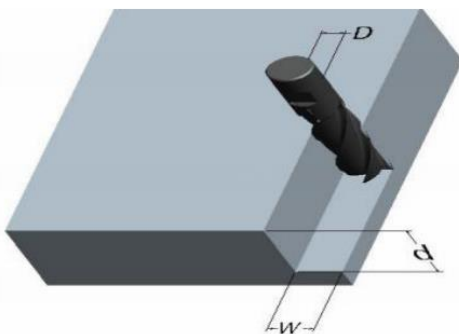

Figure 2. 2; End milling
Source: (Anon., 2018)

2.2.2 Overview of CNC Milling Process Like most conventional mechanical CNC machining processes, the CNC milling process utilizes

computerized controls to operate and manipulate machine tools which cut and shape stock material. In addition, the process follows the same basic production stages which all CNC machining processes do, including: Designing a CAD model., Converting the CAD model into a CNC program., Setting up the CNC milling machine., Executing the milling operation. The CNC milling process begins with the creation of a 2D or 3D CAD part design. Then the completed design is exported to a CNC-compatible file format and converted by CAM software into a CNC machine program which dictates the actions of the machine and the movements of the tooling across the work piece. Before the operator runs the CNC program, they prepare the CNC milling machine by affixing the work piece to the machine's work surface (i.e., worktable) or work holding device (e.g., vise), and attaching the milling tools to the machine spindle. The CNC milling process employs horizontal or vertical CNC-enabled milling machines—depending on the specifications and requirements of the milling application—and rotating multi-point (i.e., multi-toothed) cutting tools, such as mills and drills. When the machine is ready, the operator launches the program via the machine interface prompting the machine to execute the milling operation. 12 Once the CNC milling process is initiated, the machine begins rotating the cutting tool at speeds reaching up to thousands of RPM. Depending on the type of milling machine employed and the requirements of the milling application, as the tool cuts into the work piece, the machine will perform one of the following actions to produce the necessary cuts on the work piece:

- Slowly feed the work piece into the stationary, rotating tool.
- Move the tool across the stationary work piece.
- Move both the tool and work piece in relation to each other. As opposed to manual milling processes, in CNC milling, typically the machine feeds moveable work pieces with the rotation of

the cutting tool rather than against it. Milling operations which abide by this convention are known as climb milling processes, while contrary operations are known as conventional milling processes. Generally, milling is best suited as a secondary or finishing process for an already machined work piece, providing definition to or producing the part's features, such as holes, slots, and threads. However, the process is also used to shape a stock piece of material from start to finish. In both cases, the milling process gradually removes material to form the desired shape and form of the part. First, the tool cuts small pieces—i.e., chips—off the work piece to form the approximate shape and form. Then, the work piece undergoes the milling process at much higher accuracy and with greater precision to finish the part with its exact features and specifications. Typically, a completed part requires several machining passes to achieve the desired precision and tolerances. For more geometrically complex parts, multiple machine setups may be required to complete the fabrication process.

2.3 Related works

This section highlights the various types of 3 axis CNC milling machines available on the markets.

2.3.1 Types of 3 axis CNC milling machines

There are several different types of milling machines available which are suitable for a variety of machining applications. Beyond classification based solely on either machine configuration or the number of axes of motion, milling machines are further classified based on the combination of their specific characteristics. Some of the most common types of milling machines include: 1) Knee-type. 2) Ram-type. 3) Bed-type (or manufacturing-type). 4) Planer-type. 13

2.3.1.1 Knee-type.

Knee-type milling machines employ a fixed spindle and vertically adjustable worktable which rests on the saddle supported by the knee. The knee can be lowered and raised on the

column depending on the position of the machine tool. Some examples of knee-type milling machines include floor-mounted and bench-type plain horizontal milling machines.



Figure 2. 3: Knee type 3-axis CNC machine
Source: (Anon., 2016)

2.3.1.2 Ram-type:

Ram-type milling machines employ a spindle affixed to a movable housing (i.e., ram) on the column, which allows the machine tool to move along the XY axes. Two of the most common ram-type milling machines include floor-mounted universal horizontal and swivel cutter head milling machines.



Figure 2. 4: Ram type 3-axis CNC machine
Source: (Anon., 2016)

2.3.1.3 Bed-type.

Bed-type milling machines employ worktables affixed directly to the machine bed, which prevents the work piece from moving along both the Y-axis and Z-axis. The work piece is

positioned beneath the cutting tool, which, depending on the machine, is capable of moving along the XYZ axes. Some of the bed-type milling machines available include simplex, duplex, and triplex milling machines. While simplex machines employ one spindle which moves along either the X-axis or Y-axis, duplex machines employ two spindles, and triplex machines employ three spindles (two horizontal and one vertical) for machining along the XY and XYZ axes, respectively



Figure 2. 5: Bed type 3-axis CNC machine

Source: (Anon., 2016)

2.3.1.4 Planer-type. Planer-type milling machines are similar to bed-type milling machines in that they have worktables fixed along the Y-axis and Z-axis and spindles capable of moving along the XYZ axes. However, planer-type machines can support multiple machine tools (typically up to four) simultaneously, which reduces the lead time for complex parts.



Figure 2. 6: planet type 3-axis CNC machine

Source: (Anon., 2016)

2.3.2 FURTHER RELATED PROJECTS 2.3.2.1
Global level of CNC 3-axis Milling Machines. At global level for instance China, advanced three axis CNC milling machines have been developed with the power to enable fabulous detailed and elegant wooden sculptures, luxurious architectural pieces and interior design, and mind-blowingly beautiful woodworking achievements, and all dirt cheap with a machine doing all the work. Below are some of the pictures of the already developed 3 axis CNC machines; 1) Multi Head CNC Router Wood Carving Machine. Multi Head CNC Router Wood Carving Machine Suitable for wooden door and furniture, windows, tables and chairs, cabinets and panels, 3D wave plate, computer desk, musical instruments, billboard, logo, sign, 3D characters cutting, acrylic cutting, LED/neon channel, literal-hole cut, light box mold, stamp.



Figure 2.: Multi Head Cnc Router Wood Carving Machine.

Source: (Anon., 2019)

Below are some of the products designed by ATM CNC router machine.

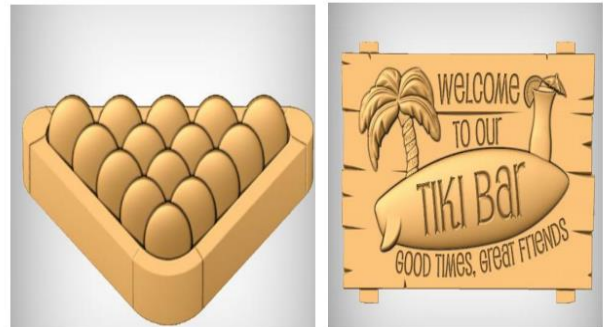

Figure 2. wooden carved pictures

Source: (Anon., 2019)

Below are some of the products designed using the multi head CNC router wood carving machine.



Figure 2. wooden carved picture

Source: (Anon., p. 2015)

2) ATC CNC router Woodworking Cutting Machine. ATC CNC router Woodworking Cutting Machine and drilling machine suitable for wooden door and furniture, windows, tables and chairs, cabinets and panels, 3D wave plat, computer desk, musical instruments

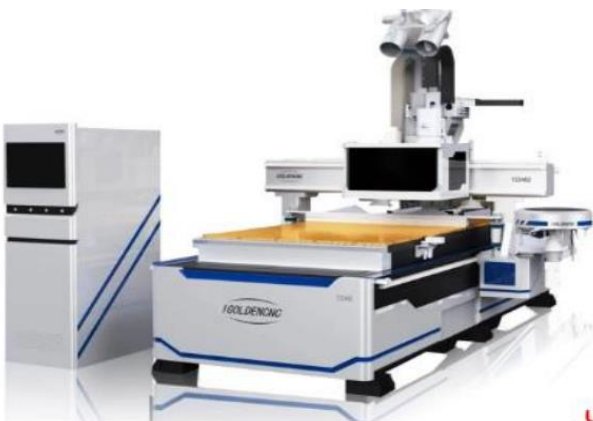

Figure 2. ATC CNC router Woodworking Cutting Machine.

Source: Source: (Anon., 2019)

2.3.2.2 Regional level of CNC 3-axis Milling Machines. The following projects on 3 axis CNC machines was done at regional level specifically in Africa 1) Low cost 3 axis CNC machine was done by two masters student namely Adel Messaoudi and Billal Belhocine at University M 'hamed Bougara – Boumerde in Algeria. (BELHOCINE, 2016)



Figure 2. 7: Adel M. CNC machine.

Source : (BELHOCINE, 2016)

2) In this section a review of what other students have done on 3 axis CNC milling machines will be presented 3- axis wood router was done by Sashank Thapha at master 's degree at Thapar University in Algeria. (BELHOCINE, 2016)



Figure 2. 8: wood router.

Source: (BELHOCINE, 2016)

2.3.2. Local level Wood carving CNC 3-axis Milling Machines. Locally people are still practicing conversational methods of wood carving. Only few companies own three axis CNC milling machines such as Mufulira Mopani mine workshop and at TAZARA Mpika workshop. The pictures are shown below. 2.4 Applications of CNC machines CNC Machining has revolutionized the manufacturing industry. Whether it is a small manufacturing unit or a large global company, CNC machines find applications in almost all types of industries. That is because when it comes to producing complex parts in metal or any other material, these computer-controlled machine tools are ideal because of their high levels of accuracy, precision and speed. So, take a look at the various industries where CNC is used. Metal Removal Applications – CNC machines are extensively used in industries where metal removal is required. The machines remove excess metal from raw materials to create complex parts. A good example of this would be the automotive industries where gears, shafts and other complex parts are carved from the raw material. CNC machines are also used in the manufacturing industries for producing rectangular, square, rounded and even threaded jobs. Metal Fabrication Industry – Many industries require thin

plates for different purposes. These industries use CNC machines for a number of machining operations such as plasma or flame cutting, laser cutting, shearing, forming and welding to create these plates. Electrical Discharge Machines (EDMs) remove metal from the raw material by producing sparks that burn away the excess metal. EDM machining through CNC automation is carried out in two different ways; first through Wire EDM and second through Vertical EDM. Besides these industries, CNC machines also find use in the wood working industries for various operations like drilling and routing.

3.0. METHODOLOGY

3.1 Introduction

This chapter is dedicated to the design and analysis of the mini three axis computer-controlled machine (CNC). It briefly describes all the components used in relation to the entire system operation. Furthermore, this chapter sheds more light on the mechanical, electrical and electronics connections and finally on the software programming for the CNC machine. 3.2 Design Concept Below are the critical components that comprise a CNC Milling machine and how each component functions in relation to the other components. 3.2.1 Control panel: Control panel is the brain of a CNC milling machine. The machinist/controller feeds the G-code (required dimensions) using the keyboard which, in turn, instructs the axis motors to move the cutters and other components. 3.2.2 Pallet The pallet is used to hold the work piece stationary for the entirety of the milling process. 3.2.3 Column The columns run along the axis to give a backbone to the milling part. 3.2.4 Cutting tool: A cutting CNC machine tool is attached to the column. It moves across the axis to give the desired shape to the CNC machined parts. 3.2.5 Frame: As the name suggests, the frame gives sturdy support to the machine, providing them with maximum rigidity to withstand

cutting forces. It is mainly built using cast iron.

3.2.6 Axes: The axes in a CNC milling machine allows cutting tool/work piece to move around obtain the maximum possible precision. 24

3.2.7 Spindle: The spindle consists of a rotating assembly that holds the cutting tool and a motor that runs the entire work piece.

3.2.8 Coolant Supply tube: The coolant supply tubes are used to cool down the rapidly heating metal work piece and to lubricate the cutting tool for smooth movement.

3.2.9 Stepper motor A digital signal is sent from the controller to the motor in the form of pulses, which will cause the motor to rotate through a specified angle, which causes the slide to move by the required distance.

3.2.10 Part program A series of coded instructions required to produce a part. Controls the movement of the machine tool and on/off control of auxiliary functions such as spindle rotation and coolant. The coded instructions are composed of letters, numbers and symbols.

3.2.11 Machine Control Unit The machine control unit (MCU) is the heart of a CNC system. It is used to perform the following functions:

To read the coded instructions.

- To decode the coded instructions.
- To implement interpolations (linear, circular, and helical) to generate axis motion commands.
- To feed the axis motion commands to the amplifier circuits for driving the axis mechanisms.
- To receive the feedback signals of position and speed for each drive axis.
- To implement auxiliary control functions such as coolant or spindle on/off and tool change.

25 3.2.12 Machine Tool CNC controls are used to control various types of machine tools. Regardless of which type of machine tool is controlled, it always has a slide table and a spindle to control position and speed. The machine table is controlled in the X and Y axes, while the spindle runs along the Z axis.

3.2.13 Drive System Drives are used to provide controlled motion to CNC elements A drive

system consists of amplifier circuits, drive motors, and ball lead-screws. The MCU feeds the control signals (position and speed) of each axis to the amplifier circuits. The control signals are augmented to actuate drive motors which in turn rotate the ball lead-screws to position the machine table.

3.2.14 Linear Motion Drives. Linear motion drives are mechanical transmission systems which are used to convert rotary motion into linear motion. The conventional thread forms like vee or square are not suitable in CNC because of their high wear and less efficiency. CNC machines generally employ ball screw for driving their work piece carriages. These drives provide backlash free operation with low friction wear characteristics. These are efficient and accurate in comparison with that of nut and-screw drives. Most widely used linear motion drives are ball screws. 26

3.3 Design interpretation 3.3.1 Mechanical design interpretation. The system has 3 linear axes. In these axes, transmission of motion is provided with the help of linear bearings. Radial movement which is produced by stepper motors, is transformed to linear movement by linear bearings. Stepper motors are linked to linear bearings via couplings. Axes are able to work independent from each other, at the same time interpolation process can be done with the concurrent movement of multiple axes. Technical properties of the router are shown in Table 3.1 below;

Actuator Type	Stepper motor
X, Y, Z limits	650mm,540mm,100mm
Cutting Depth	2mm
Cutting velocity	1m/min
Free velocity	3m/s

Table 3. 1: technical properties of a router

Necessary amount of motor power is calculated by regarding the general structure of the system and axes weight .

$$P = (2\pi NmTt/60) \dots\dots\dots(3.1)$$

$$P_a = (2\pi NmTt/60)^2 (J_L/t_a) \dots\dots\dots(3.2)$$

Where;

P = Motor power while cutting (W)

T_t = Total moment while cutting (Nm)

N_m = Motor speed (rpm)

P_a = Motor power while acceleration (W)

J_L = Total inertia (kg-m²)

t_a = Acceleration time (sec)

As a result of calculations, findings about motor power requirements are pointed in Table 2.2 below;

	X Axis	Y Axis	Z Axis
During acceleration(W)	16,03	13,47	5,77
During cutting(W)	30,16	15,07	39,57

Table 3. 2: Motor power requirements. 3.3.2 Drive ways designs. The purpose of the drive mechanics is to transfer the torque provided by the electric drive motors into linear motion to move the tool head. Since CNC machines require linear movement in multiple axes, threaded rods coupled with the motors, Figure 3.1, are most often used to accomplish this goal. These systems offer a simple and compact means of transmitting power and motion with excellent reliability. For these machines, the pulleys are turned by motors, generating linear motion. Threaded rods are used because they are low cost, less noise, less maintenance, higher efficiency. To ensure the machine tool components moves in its predetermined track. Guide ways are used to move the machine tool in the correct path.

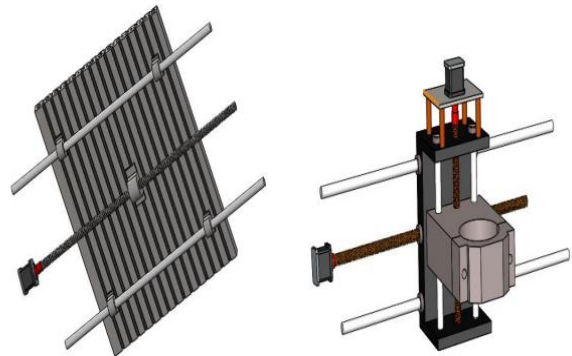

Figure 3. 1: drive design

3.3.3 Motion control methods. The purpose of motion control is to move an axis, or multiple axes, to a specified position or through a predefined path. The two methods that would discuss below are point to point motion and continuous path motion. 3.3.2.1 Point to point motion Point-to-point systems are those that move the tool or the work piece from one point to another and then the tool performs the required task. Upon completion, the tool (or work piece) moves to the next position and the cycle is repeated. The simplest example for this type of system is a frilling machine where the work piece moves. In this system, the federate and the path of the cutting tool (or work piece) have no significance on the machining process.

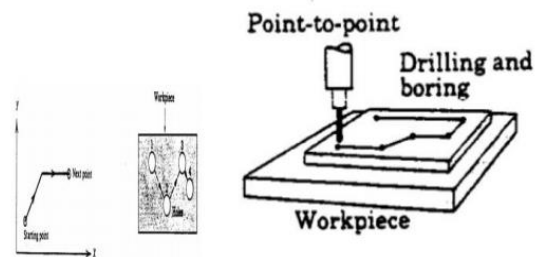

Figure 3. 2: point to point trajectory motion
Source: (BELHOCINE, 2016)

3.3.2.2 Continuous Path Motion To achieve contoured motion, a series of points is provided during programming, and the motion controller extrapolates a smooth line or curve from these points. Unlike point-to-point motion, contouring

guarantees that the system passes through each point using either linear or circular interpolation. In a contoured move, a time to complete the move is specified, but the actual move profile is determined by the motion controller. (resource, 2019).

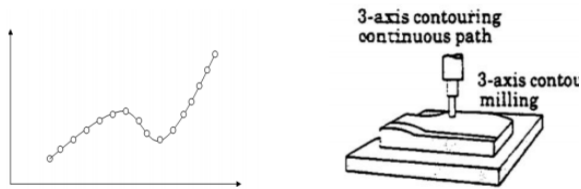

Figure 3.3: Continuous trajectory path
Source: (BELHOCINE, 2016)

3.3.2.3 Precision in CNC machining. The combined characteristics of the machine tool and the control determine the precision of positioning. Three critical measures of precision are: 1) Control Resolution (BLU) This is the distance separating two adjacent points in the axis movement (The smallest change in the position). The electromechanical components of the positioning system that affect the resolution are the lead screw pitch, the gear ratio, and the step angle in the stepping motor (open loop) or the angle between the slots in the encoder (closed-loop). The control resolution for a 1 : 1 gear ratio of a stepped motor is,

$$\text{Resolution}(R) = \frac{\text{PITCH}(P)}{360/\alpha} \dots\dots\dots(3.3)$$

Features smaller than the control resolution could not be produced. The programming resolution cannot exceed the control resolution. 2) Accuracy The accuracy of CNC system depends on the resolution, the computer control algorithms, and the machine inaccuracies. The inaccuracy due to the resolution is considered to be (1/2) BLU on the average. The control algorithm inaccuracy is due to the rounding off the errors in the computer which is insignificant. The machine inaccuracy could be due to several reasons (Described below). The designer minimizes this inaccuracy to be under (1/2) BLU and hence Machining Inaccuracy.

$$\text{Accuracy} = (1/2) \text{ Resolution} + \text{Machining inaccuracy} = \text{BLU}$$

3) Repeatability It refers to the capability of a positioning system to return to a programmed point, and is measured in terms of the errors associated with the programmed point. The deviation from the control point (error) usually follows a normal distribution in which case the repeatability may be given as $\pm 3\sigma$ where σ is the standard deviation. The repeatability is always better than the accuracy. The mechanical inaccuracy can be considered as the repeatability. Cutting tool deflection, machine tool chatter, mechanical linkage between the lead screw and the tool, and thermal deformations are the chief contributing factors. The lead screw transmits the power to the table or tool holder by means of a nut that engages the lead screw. This will create what is known as "backlash" due to the friction between the screw and the nut. If the nut consists of ball bearings, the friction is reduced. Thermal deformations are significant 3.3 System Block Diagram On this section, we discuss the overall block diagram of the system in the figure below;

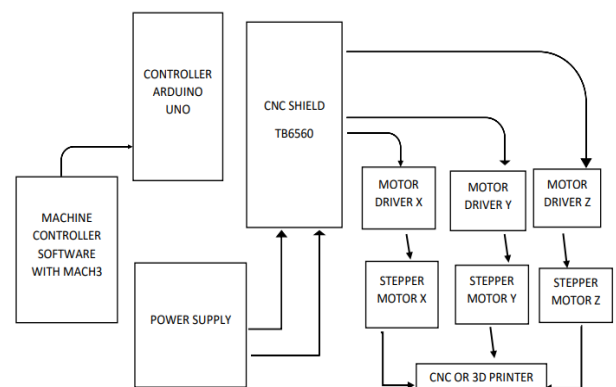

Figure 3.4: system block diagram

The three-core parts of the CNC system are mechanical tools, electrical and electronics and finally the software programming. 3.4 Bubble Diagram



3.5 Material selection Some of the most common and analytical methods of materials selection are: 1. Cost versus Performance 2. Weighted Property Indices 3. Value Analysis 4. Failure Analysis 5. Benefit -Cost Analysis 1. Cost vs Performance Because cost was so important in selecting materials, it was logical to consider cost at the start of the material selection process. Usually, a target cost was set to eliminate the materials that were expensive. The final choice was a trade -off between cost and performance. The materials properties of interest are mechanical strength (expressed as tensile yield strength), the machinability (the ease of machining affects CNC pricing), material cost, the hardness (mainly for metals). The following were the materials selected: 1) Aluminum alloy Aluminum alloys have an excellent strength-to-weight ratio, a high thermal and electrical conductivity and natural protection against corrosion. They can be easily machined and have a low bulk cost, so they are often the most economical option of creating custom metal parts and prototypes typically, aluminum 6061 is the most common, general-use aluminum alloy, with good strength-to-weight ratio and excellent machinability

2) Steel. Steel alloys have high strength, high ductility, excellent wear and corrosion resistance and can be easily welded, machined and polished. Depending on their composition, they can be either (essentially) non-magnetic or magnetic.

3.5.1 Slide selection Factors to be considered for slide selection include: 1. Length of stroke and size 2. Mounting orientation 3. Load to be carried out 4. Maximum velocity 5. Acceleration and deceleration rate

3.5.2 Spindle Motor Selection The following points should be considered while selecting the spindle motor for the machine;

- It should run at high Rpm to cut brittle materials like wood.
- Should be air cooled instead of water cooled to avoid any moisture on wood.
- Depth and width of the cut should be known.
- Feed rate
- Diameter of the cutting tool

The selection of spindle power is followed by the calculation of tangential and axial on work material required to make machining. And these forces depend on the specific cutting force of the material and methods of machining. While machining wood the knowledge of specific cutting force becomes very difficult because of the following reasons;

- Wood varies from soft wood to hard wood.
- Properties of wood are not the same in all directions.
- Seasoning of wood improves its material properties which depend upon time and method of seasoning.

3.5.3 Frame CNC frame materials need to have some strength in order to support the weight of the gantry and the cutting head as well as with stand forces resulting from the routing process. Stiffness is also required to prevent any deflection due to both static forces and dynamic. Forces resulting

from the acceleration of the tool head. Weight is also important because the mass of the frame contributes to both the static and acceleration forces. The table below shows the parts and their choice of material;

Name of parts	Choice of material
Frame	Aluminum 6061
Pallet	Aluminum 6061
Milling tool	Steel 1020
Guide bearing	Aluminum 6061
Frame supporters	Aluminum 6061
Extruder Nozzle holder	Aluminum 6061
Guide drive	Aluminum 6061
Spindle (threaded rods)	Steel 1020
Motor bearing	Steel 1020

Table 3. 4,material specifications;

Part number	Description of requirements	Required
1	Technical specification	
1.1	Capacity	
1.1.1	Length of table	650 min
1.1.2	Width of table	400 min
1.1.3	Max load on table	300 kg
1.1.4	X travel	600 mm min
1.1.5	Y travel	400 mm min
1.1.6	Z travel	300 mm min
1.2	Machine Spindle	
1.2.1	Spindle Speed	Min 8000 Rpm
1.2.2	Main Spindle Power	7Kw or more
1.2.3	Spindle taper	ISO/BT/SK 40/50
1.3	Accuracy	
1.3.1	Positional accuracy	0.01 mm in full length
1.3.1	Repeatability	0.005 or better
1.4	Axis drive and Control	
1.4.1	Digital controlled drive and motors	For all Axis
1.4.2	Guide way	LM guide way
1.4.3	Rapid Speed	Min 20m/min
1.4.4	Feed rate	Min 6m/min

3.6.2 Electronic tools

Motor driver controller TB6560 board. NEMA 17 Bipolar Stepper Motors 76 oz MK8 Extruder Nozzle (1.75 mm Printer Head) or J-Head Hotend (1.75 mm) Filament Bowden Extruder Nozzle 0.4 mm Printer Kit RAMPS (1.4 Board + LCD 2004 + MEGA 2560 Module + 5 x A4988) 3.6.3 Frame specifications Stepper Motor Mounts Printer filament 1.75mm 3mm ABS/PLA Arc threaded rod (diameter 15 x 540 mm) A lot of Screws, Nuts and Washers Linear Shaft Bearings 12m Linear Rail

Shafts (Q15mmx 650mm) 3.7 Electronics connections

3.7.1 Introduction This section will cover all the electronics and electrical components involved with a CNC router and help to understand how they are wired to each other to create a working machine.

3.7.2 Stepper Motor A stepper motor is an electromechanical device which converts electrical pulses into discrete mechanical movements. The shaft or spindle of a stepper motor rotates in discrete step increments when electrical command pulses are applied to it in the proper sequence. The motors rotation has several direct relationships to these applied input pulses. The sequence of the applied pulses is directly related to the direction of motor shafts rotation. The speed of the motor shafts rotation is directly related to the frequency of the input pulses and the angular rotation is directly related to the number of input pulses applied. Like any other motors, the stepper motors consist of a stator and a rotor as shown in figure 3.5, below. The rotor carries a set of permanent magnets, and the stator has the coils. In our project, when working with a motor, a few steps need to be taken to get it moving correctly;

- Get the number of steps per revolution (by knowing the angle of the motor)
- Decide on micro-stepping value (depends on the motor driver specifications)
- Calculate steps per mm
- Move the carriage for a known distance
- Measure error and apply to settings

36 Firstly, initial steps/mm is calculated. This step will not be necessary if using a mill with known geometries, just take the steps/mm as given in datasheet. But as in our project, if using recycled parts or variable materials (like belts), some basic math is needed to get an approximate first calculation. This step should be done for each axis. While turning the motor, measure the distance traveled in mm. Then, calculate steps per mm based on:

$$\text{Steps per millimeters} = \frac{\frac{\text{Steps per revolution}}{\text{mm per revolution}}}{\text{micro-stepping fraction}} \dots\dots\dots(3.4)$$

The program in the microcontroller instructs the head of CNC (spindle) to move 2 cm (or some number of millimeters) where the number of steps is 761.9 (20*39.09). If closed, reset the head, mark the location and repeat. Make a measurement of the true movement. Finally, modify the original calculation (initial steps/mm) by a ratio of the expected and measured movement. Another way to think of it is what is the percent error?

$$\text{Calculations}_{\text{new}} = \text{Calculations}_{\text{Initial}} \times \frac{\text{distance}_{\text{traveled}}}{\text{distance}_{\text{measured}}} \dots\dots\dots(3.5)$$

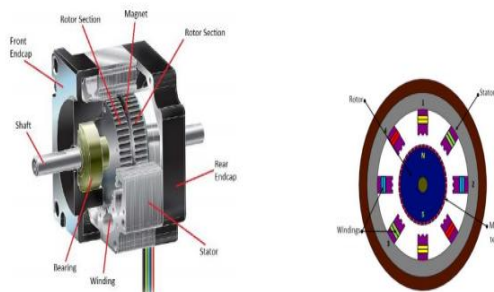

Figure 3.6 : hybrid stepper motor
Source: (Anon., 2016)

3.7.3 Stepper Motor Driver Board The stepper motor driver receives step and direction signals from the microcontroller and converts them into rated high voltage electrical signals to run the stepper motor. The single-axis TB6560 stepper motor driver is used for each axis of motion. These boards were used in our 37 projects so that in the case of motor drive problems the single boards can be swapped out, without the trouble of replacing an entire multi-axis driver board. The terminal connections were made by connecting the corresponding pins from the driver with the microcontroller (Arduino). The DC power supply is connected between +24V and Ground, and the motor Phase A-B windings are connected between A+ and A-, B+ and B-. The CLK+ and CW+ of each

axis are connected to the Arduino as illustrated in figure 3.6. Figure 3.6, also showed the pins assigned for axis pulse signal and direction signal. The CLK-, CW- and EN pins are connected to ground. There are many different kinds of motor drivers, the one used in this project is the TB6560 whose image is shown in figure 3.6, below;

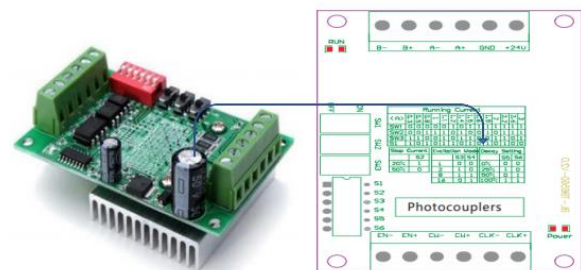

Figure 3.7: TB6560 stepper motor circuit board
SOURCE: (Sriranga V Deshpande1, 2018)

3.7.3.1 Pin Connections of TB6560

Table 3.4, shows the current range of the stepper motor.

Running current														
Amps(A)	0.3	0.5	0.8	1	1.1	1.2	1.4	1.5	1.6	1.9	2	2.2	2.6	3
Sw1	0	0	0	0	0	1	0	1	1	1	1	1	1	1
Sw2	0	0	1	1	1	0	1	0	0	1	0	1	1	1
Sw3	1	1	0	0	1	0	1	1	0	0	1	1	0	1
S1	1	0	1	0	1	1	0	1	0	1	0	1	0	0

Table 3.5: current range of the stepper motor drive TB6560

Note: Each switch has two states the on and off states. The on state is represented by 1 and the off state is represented by 0 From table 3.4, sw1 to sw3 and s1 represents the switch names and the first row represents the current range in amperes. Depending with the stepper motor used, appropriate current can be set following the switch conditions above. For instance, if your motor is rated 2.6 A, the switch conditions should be set as sw1=1, sw2=1, sw3=0 and s1=0 Table 3.5, shows the stop current of the TB6560.

Stop current	
	S2
20%	1
50%	0

Table 3. 6: stop current of the TB6560.

Table 3.5, above helps us to set for the motor the stop current when the motors are stand still or simply the off conditions of the motor so that they maintain their positions. Table 3.6 shows the excitation modes of the stepper motor.

Excitation mode		
step	S3	S4
whole	0	0
half	1	0
1/8	1	1
1/16	0	1

Table 3. 7: excitation modes of the stepper motor.

Table 3.6, shows the micro settings of the chip, the higher the excitation state the higher the holding torque (a force that causes rotational motion) of the motor as well as the higher the resolution you get on the CNC machine. Table 3.7, below shows the decay settings of the stepper motor drive TB6560

Decay settings		
	S5	S6
0% (low)	0	0
25%	1	0
50%	0	1
100% (fast)	1	1

Table 3. 8: Decay settings of the stepper motor drive TB6560

From table 3.7, the fast decay settings allow the current to go direct to the power supply when you stop the device. This allows the magnetic field to collapse quickly. This in turn allows for higher motor speeds. Th lower decay settings, you feed current from the engine back to itself, this in turn causes the field to collapse slowly as a result the motor will stop instantly. This mode limits the motor speed. 3.7.3.2 TB6560 features The TB6560

stepper motor driver has some features and characteristic. · Low cost and good high-speed torque. · Supply voltage up to +32 VDC. · Output current up to 3.0A. · Pulse frequency up to 20 KHz. · Suitable for 2-phase and 4-phase motors. · Over-voltage and short-circuit protection. · 7 output current choices, max 3200 steps/rev. · Automatic idle-current reduction. · Slim size (96x61x37mm).

3.7.4 Advantages of stepper motors · Low cost · Ruggedness · Simplicity of construction · Low maintenance · Less likely to stall or slip · Will work in any environment · Excellent start-stop and reversing responses

3.7.5 Disadvantages of stepper motors · Low torque capacity compared to DC motors · Limited speed 40 · During overloading, the synchronization will be broken. Vibration and noise occur when running at high speed.

3.7.6 Arduino kit Arduino is an open-source prototyping platform based in easy-to-use hardware and software. Arduino boards are able to read inputs – light-on sensor, a finger on a button or a Twitter message – and turn it into an output– activating of a motor, turning on an LED, publishing something online. You can tell your board what to do by sending a set of instructions to the microcontroller on the board. To do so, you use the Arduino programming language (based on Wiring) and the Arduino® software IDE (based on Processing).in our case, the Arduino kid will be used to control the speed of the stepper motors. Figure 3.7 and figure 3.8, shows the Arduino pinouts and its schematic diagram (electronics, 2019). The Arduino comes in many variations, and it is based either on an 8-bit Atmel AVR microcontroller or on a32-bit Atmel ARM. An Arduino will be used to control the CNC router machine that will be built. The latest version is the Arduino UNO (Figure 3.8) based on the 8-bit Atmel ATMEGA328 microcontroller. UNO does not need a separate piece of hardware (called a programmer) in order to load a new code onto it simply use a USB cable.

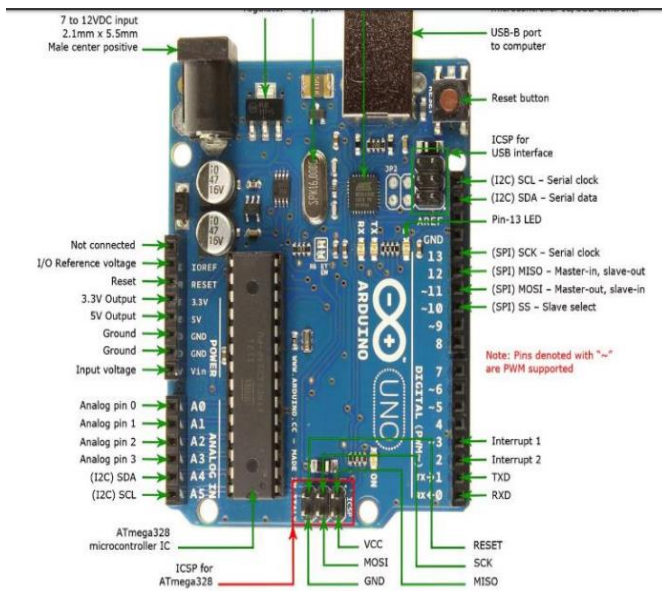

3.7.6.1 Arduino Uno specifications

Table 2-2 shows the characteristics of the Uno board used in our project.

Microcontroller	ATmega328	DC Current per I/O pin	40 mA
Operating voltage pin	5V	DC Current for 3.3V pin	50mA

Input voltage	7-12V	Flash memory	32 Kbytes
Input voltage(limit)	6-20V	SRAM	2 Kbytes
Digital I/O pins	14	EEPROM	1 Kbytes
PWM Digital I/O pins	6	Clock Speed	16 MHz
Analog input Pins	6	Bootloader size	0.5 Kbytes

Table 2-2 Arduino UNO specifications [16].

3.7.6.2 Arduino Programming Language Using C to program the Arduino means usually being able to create smaller programs, and with more fine-grained control of what happens. C is adopted worldwide to program for small microprocessors because it gives a good trade-off between development effort and program efficiency, and because of its history there are well-optimized libraries, extensive guides and ways to solve problems. Arduino IDE uses the avr-gcc compiler and the avrdude uploading tool. The Arduino IDE preference contains verbosity options that have the effect of printing the commands that are run while the program is compiled and uploaded. This was very useful to understand what the graphical user interface is doing, which turns out is a common workflow for C and C++ builds.

3.7.7 Connections

of an Arduino uno to TB6560 Driver using one phase

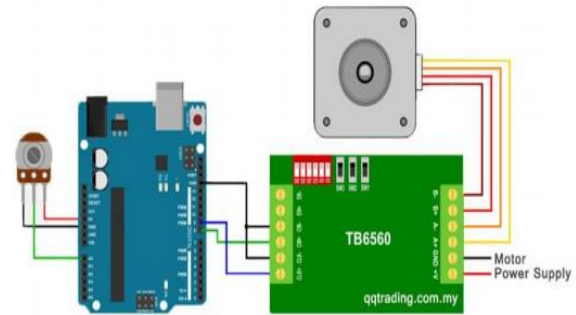

Figure 3.9: circuit wiring connections

Source: (Anon., p. 2015)

Figure 3.10, shows connections of a LIQUID CRISTAL DISPLAY(LCD) to the arduino uno board

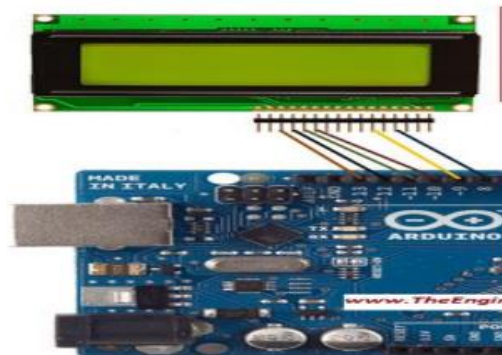

Figure 3. 10 : LCD pin connections to an Arduino Uno

Source: Source: (Anon., p. 2015)

3.7.7 G-CODE. G-Code or Geometric Code is the generic name for a control language for CNC machines. It is a way to tell the machine to move to various points at a desired speed, control the spindle speed, turn on and off various coolants, and all sorts of other things. It is fairly standard, and is a useful tool. The standard version of G-code is known as RS-274D. Since G-codes are preparatory codes, in a CNC program they begin with the letter G and direct the machine. Typical actions Gcode directs include;

- Changing a pallet.
- Rapid movement.
- A series of controlled feed moves, resulting in a workpiece cut, a bored hole, or a decorative profile shape.
- Controlling feed movement, in an arc or a straight line.
- Setting tool information.

3.7.7.1 How

G-CODE Works In order to achieve these particular kinds of movement, Numerical Control uses a block as its basic unit—when printed, it resembles a line of text. Each block carries one or more words (of sorts) each consisting of a letter—detailing the function to be performed— followed by a number that assigns value to the function. Currently, a block of input is limited to a maximum of 256 characters. Below are some common individual codes, that when combined, guide a machine 's movement. · G00: Rapid positioning This code causes the machine to operate at a high speed. 44 · G01: Linear interpolation. The machine will move in a straight line, performing the appropriate machining (milling, cutting, etc.). · G02: Circular/Helical Interpolation The machine will move clockwise in a circular or helical pattern, performing the appropriate machining process · G03: Circular/Helical Interpolation This code is the same as G02, but enables counterclockwise movement. · G17: X-Y plane selection. · G18: X-Z plane selection. · G19: Y-Z plane selection These codes maneuver the machine onto different planes for coordinated motion. · G20: Programming in inches · G21: Programming in mm Changes in programming units occur short-term with these particular codes. The above codes are the same for both milling and turning, but other units may vary. In terms of software specifications, most g-code files can be created using CAM, but certain CNC machines rely on —conversational programming, which either hides or bypasses the use of g-code completely. 3.7.8 Power Supply Power supply is heart of the CNC system which converts the AC voltage to DC voltage and supplies required voltages to the corresponding devices. In this project, four AC/DC adapters were used. Three of them for powering stepper motors through their drivers (5V – 400mA) and the fourth one to power the Raspberry pi 2 model B (5V – 2A). 3.7.9 GRBL Controller Setup: GRBL controller is mostly used in DIY CNC Controller. The software runs the machine very smoothly with excellent acceleration

& deceleration control. GRBL looks for lines of Gcode passed over USB and also manages all of the timing necessary. a) Preparing GRBL · Power up Arduino and shield. · With motor off, manually position milling bit over origin (0,0) on the work piece. The origin is the intersection of X and Y on your CAD drawing. · Start GRBL Controller. · Select COM port and open. b) Adjusting GRBL · Choose appropriate step size (start with 1) · Press the Z down button, the milling bit should move down towards the work piece 1 mm. The Z jog speed can be adjusted in menu Tools -> Options · Repeat until the bit is almost touching 45 · Turn on motor. · Press GRBL Controller 's Reset button to zero the Arduino GRBL code. c) Sending G-code: · Choose Send G-Code radio button. · Open desired file, usually.nc. · Press Begin. If for some reason there is a long, slow traverse, the controller may time out. Increase timeout value in Tools -> Options. d) Finish: · Turn off motor when milling is complete. e) Emergency: · Press the Reset, Stop or Close button on GRBL Controller - the steppers should stop within a second or two. If not, power off your shield. 3.7.9.1 Features Some important features of GRBL are: I. It enables communication over USB. II. GRBL has many advanced parameters that many beginners will not need. However, these functions allow the user to grow into using the full capabilities of their machine. 3.3.7.9.2 Limitation of GRBL · Backlash compensation: In any machine there is —slop which is a technical term. Due to the mechanical components of the system, Backlash is lost motion. Backlash compensation is a way to tell the software how much lost motion the machine has in the x, y & z-axis. The machine controller will use these values each time the machine changes direction to improve the precision of the motion. · Grbl supports 3-axis of motion (x, y, z). But it does not support rotation axes. · Tuning GRBL can be somewhat intimidating. Additional Items for GRBL: To create a NC controller using GRBL software, we need a few additional items mentioned below. · Arduino:

To host the GRBL software. · Stepper Motors: These provide the motion to move your machine. · Stepper Motor Drivers: The Bridge between the Arduino and stepper motors that move the machine. · Power supply: connect to the stepper motor drivers and provides the power to the drivers & stepper motors. · Computer: To have a USB connection between a computer and the Arduino. · G-Code Parser (Software): To upload a Gcode file. This software sends the file one line at time to the GRBL software.

46 3.3.7.9.3 GRBL Settings First Step Figure 7 below shows installation of Universal Gcode Sender and GRBL

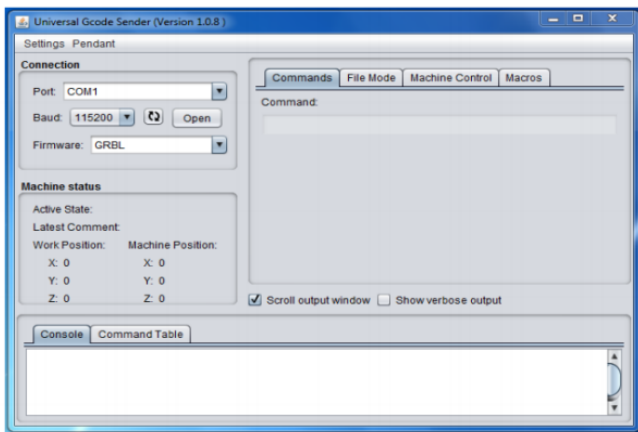

Figure 3. 11: universal Gcode sender
Source: (Anon., 2014)

3.3.7.9.3.1 Display Current GRBL Settings To get our CNC machines to do exactly what we want, there are quite a few GRBL settings that we can adjust. While setting up the machine as opposed to going back and searching the GRBL wiki page, it's easier to refer back to a single sheet. By Typing —\$\$, we can see the current settings. It displays the available user defined settings in the console window. Here, we are interested in the —Steps/mm settings. \$100=314.961 (x, step/mm) \$101=314.961 (y, step/mm) \$102=78.740 (z, step/mm) Important thing to remember that these were not the default settings on the system. To get 314.961: Lead Screw Pitch = .200 inches (inches per revolution) Stepper Motor # of Steps per Revolution = 200 (steps/revolution) Micro Stepping Setting = 8X 47 For example, let's use a .200-inch

pitch lead screws, stepper motors of 200 steps per revolution and the stepper motor controller is set to 8X micro stepping for the x & y axis. 3.3.7.9.3.1 Calculating the “step/mm” Value Let ‘s break it down one step at a time. Step 1 Divide the number of steps per revolution by the lead screw pitch.

$$\frac{\# \text{ of steps per revolution}}{\text{lead screw pitch}} = \frac{200 \left(\frac{\text{steps}}{\text{revolution}} \right)}{.200 \left(\frac{\text{inches}}{\text{revolution}} \right)} = 1000 \left(\frac{\text{steps}}{\text{inch}} \right)$$

Step 2

Divide the number of steps per inch by 25.4 to convert to steps per mm.

$$\frac{\# \text{ of steps per revolution}}{\text{inch}} \times \frac{1 \text{ inch}}{25.4 \text{ mm}} = \frac{1000 \text{ steps}}{\text{inch}} \times \frac{1 \text{ inch}}{25.4 \text{ mm}} = 39.37 \left(\frac{\text{steps}}{\text{mm}} \right)$$

Step 3

Multiplying the steps per mm by the micro stepping setting;

$$\frac{\# \text{ of steps}}{\text{inch}} \times \text{micro stepping} = 39.37 \left(\frac{\text{steps}}{\text{mm}} \right) \times 8 = 314.96 \left(\frac{\text{steps}}{\text{mm}} \right)$$

After a few quick calculations we have the values we need. Update the GRBL settings by typing the following into the command line. \$100 = 314.961 This will set the X axis steps per mm. Repeat the process for the Y and Z axis using \$101 and \$102 respectively. Important thing to remember that the Z axis setting is different because of running a lower micro stepping count of 2x to get a little more power to lift the head of the mill 48 3.7.9.1 Part Programming Fundamentals 1) Steps to be followed while developing CNC part programs: Process Planning Process plan is a detailed plan of the steps involved in manufacturing a given part. It includes Machine tool used Fixture required Sequence of operations Cutting tools required Process parameters 2) Axes selection All the CNC machine tools rely on the axes system for describing the axes motion. To correctly describe the motion, it is necessary to establish the axes system to be followed with the particular part. 3) Tool Selection

The choice of cutting tool is very important function, since for a given operation many tools are feasible, but some of them would be more economical than others. Therefore in the economy of manufacture, it is essential to choose the right tool for the job.

4) Cutting Process Parameters Planning For a given tool and the operation selected, the appropriate process parameters are to be selected. There are to be generally taken from the handbooks supplied by the cutting tool manufacturer or based on the shop experiences.

5) Job and tool set up planning This basically is aimed at setting job on the machine tool and adjusting the cutting tool to correct position. This is important since the accuracy of the geometry generated by the CNC machine tool is dependent on the initial position carefully defined.

6) Machining path planning A careful planning of the tool path ensures that the requisite manufacturing specifications are achieved at the lowest cost.

7) Part Program writing It deals with the actual writing of the part programs undertaking the format and syntax restrictions in to account.

8) Part program proving Once the program is made, it should be verified before it can be loaded on the machine tool controller for the manufacture of the component. A faulty program may cause damage to the tool, work piece and the machine tool itself.

9) NC documentation This is the most essential aspect of the CNC manufacturing practice. It should include: Component drawing Process planning sheet Tool cards Setting cards Programming sheets Punched paper tape

3.8 Program of Instruction When starting out with CNC, the first thing to do is creating some sort of model, drawing, or representation of the part or object to be machined. Most of the time this is a function of a CAD/CAM systems so they will generate g-code (machine commands). Computer-aided design (CAD) involves creating computer models defined by geometrical parameters. These models typically appear on a computer monitor as a three-dimensional representation of a part or a system of parts, which can be readily altered by

changing relevant parameters. CAD systems enable designers to view objects under a wide variety of representations and to test these objects by simulating real-world conditions. Computer-aided manufacturing (CAM) uses geometrical design data to control automated machinery. CAM systems are associated with computer numerical control (CNC) or direct numerical control (DNC) systems.

3.8 2-D Drawings of the parts

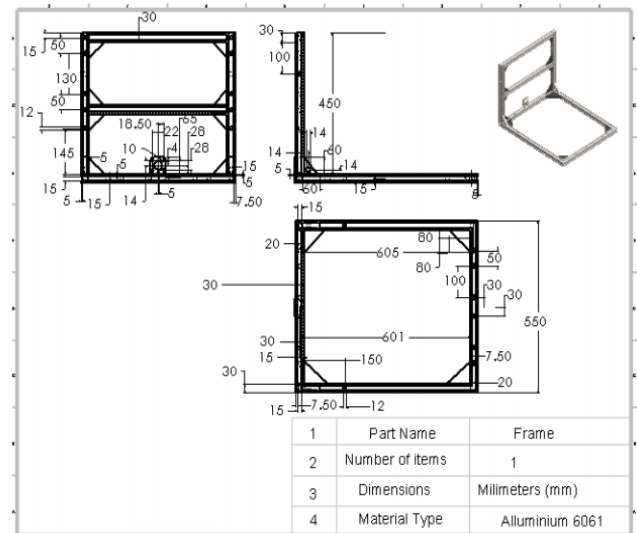

Figure 3.15: frame drawing
Source: Author 2019

3.8.2 Sheet Metal Pallet

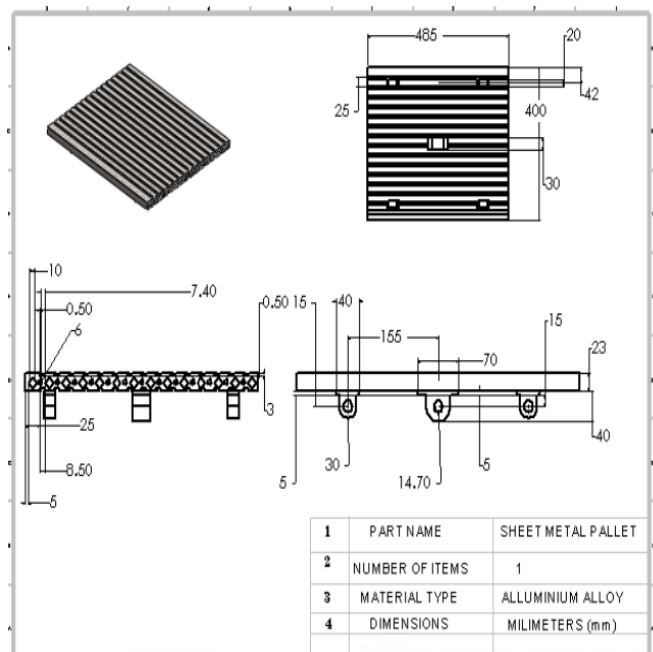

Figure 3.16: Pallet drawing

3.8.3 Guide Drive

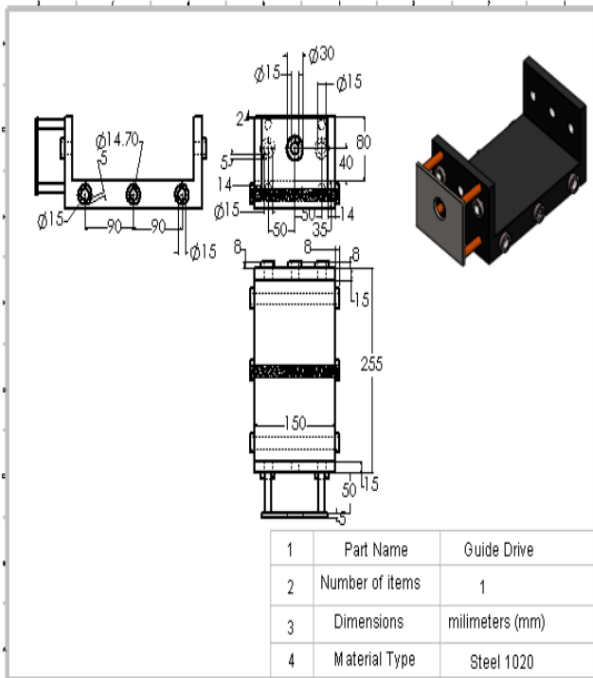

Figure 3.17: guide drive

3.8.5 Frame Supporter

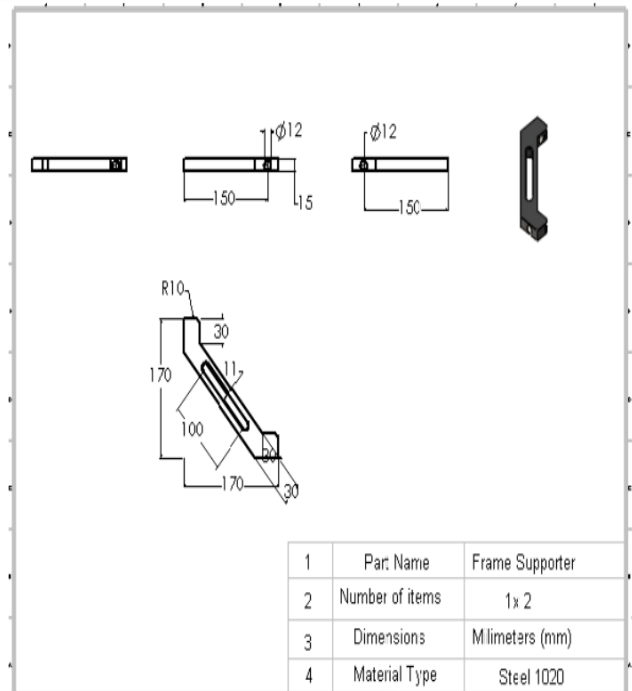

Figure 3.19: Frame supporter

3.8.4 Extruder Nozzle Holder

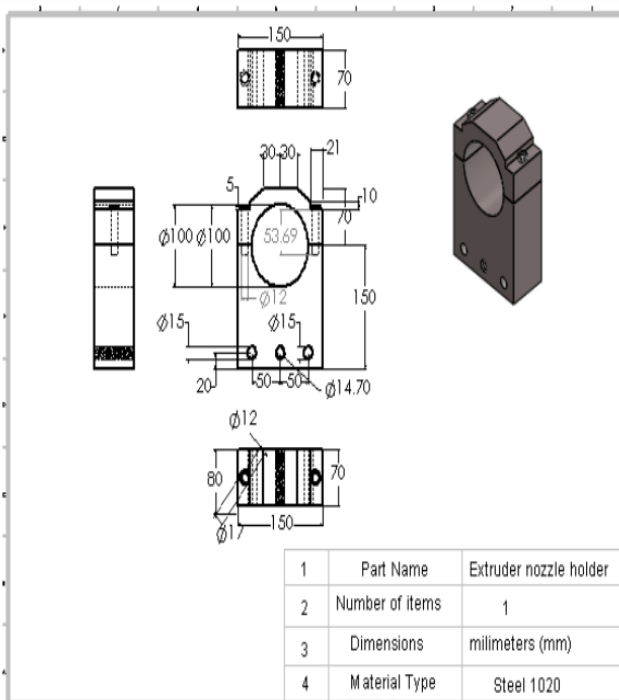

Figure 3.18: extruder nozzle holder

3.8.6 Guide Bearing

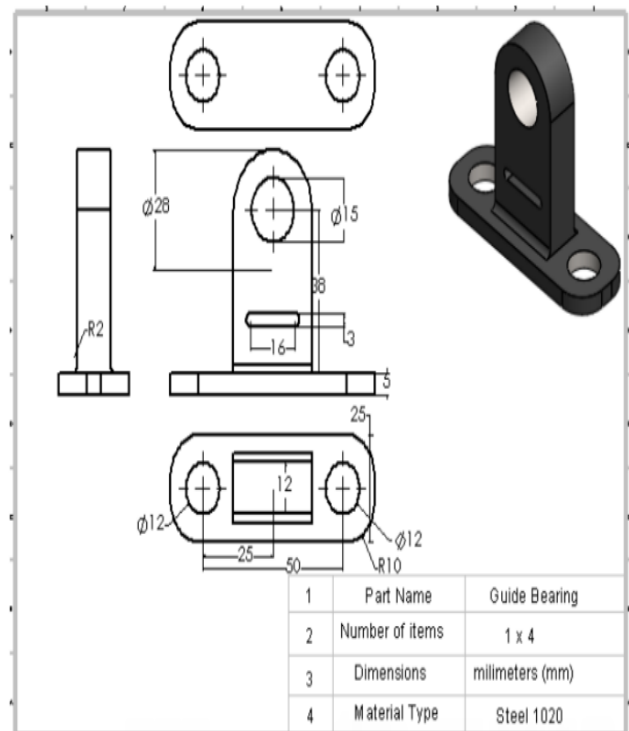

Figure 3.20: Guide Bearing

3.8.7 Milling Tool

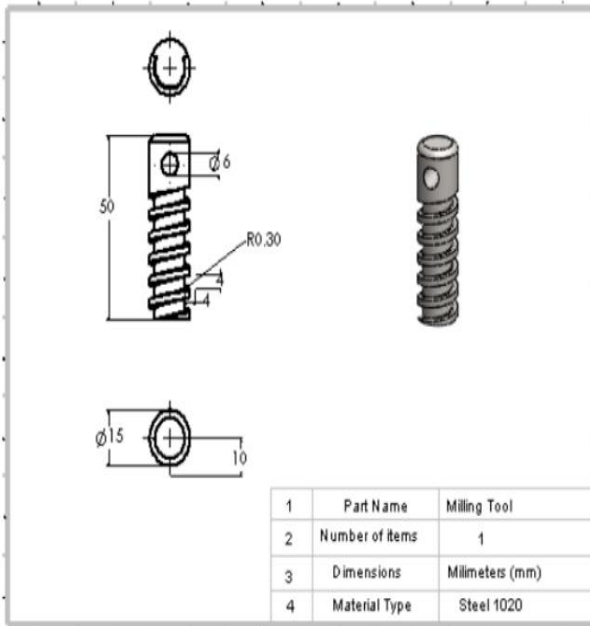
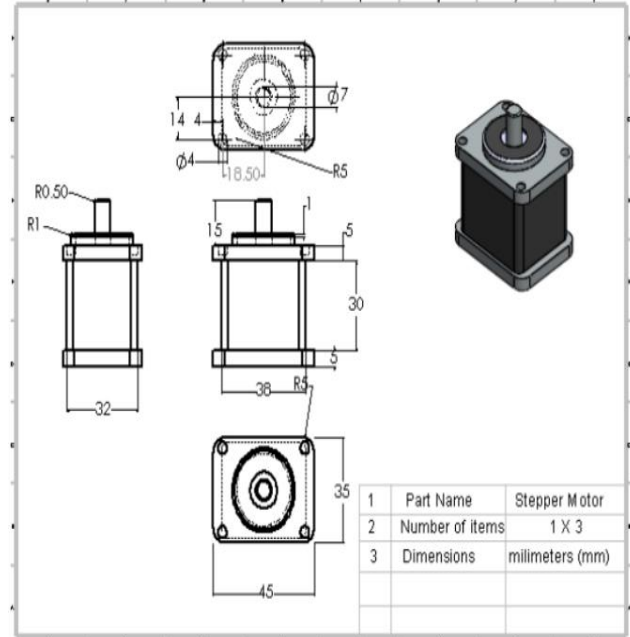
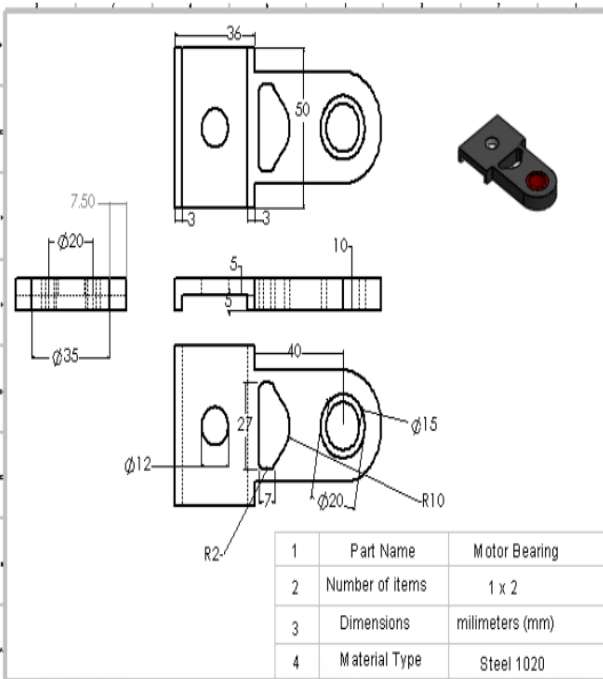

Figure 3.21: Milling tool

3.8.9 Stepper Motor



3.8.8 Motor Bearing



3.8.10 Pallet Bearing

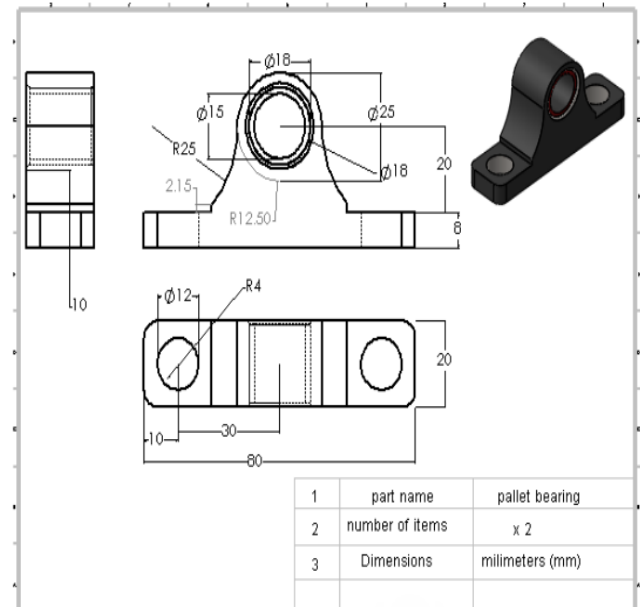

Figure 3.24: Pallet bearing

3.8.11 Guide Rod

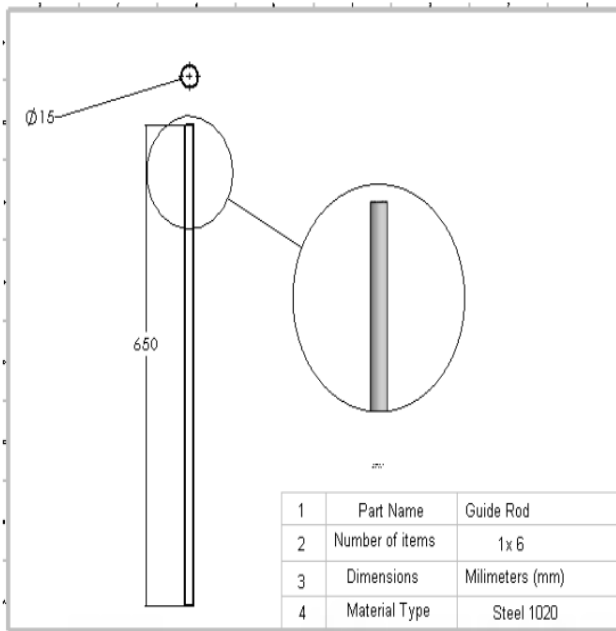

Figure 3.25: Guide rod

3.8.13 Spindle

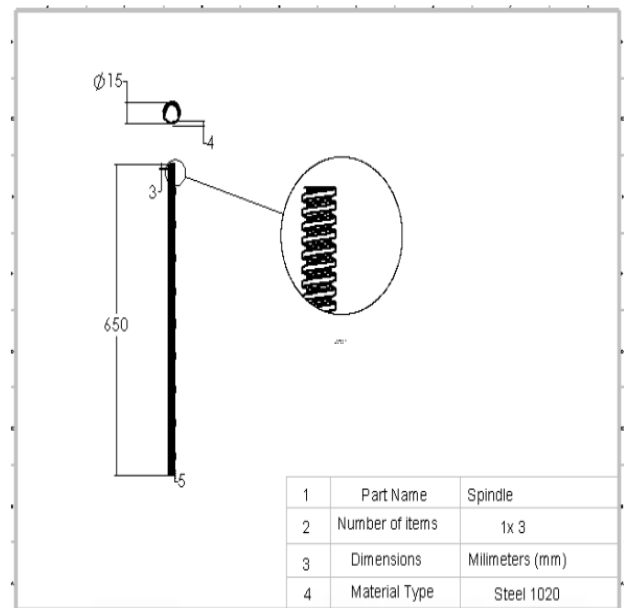

Figure 3.27: Spindle

Source: Author 2019

3.8.12 Side Bearing

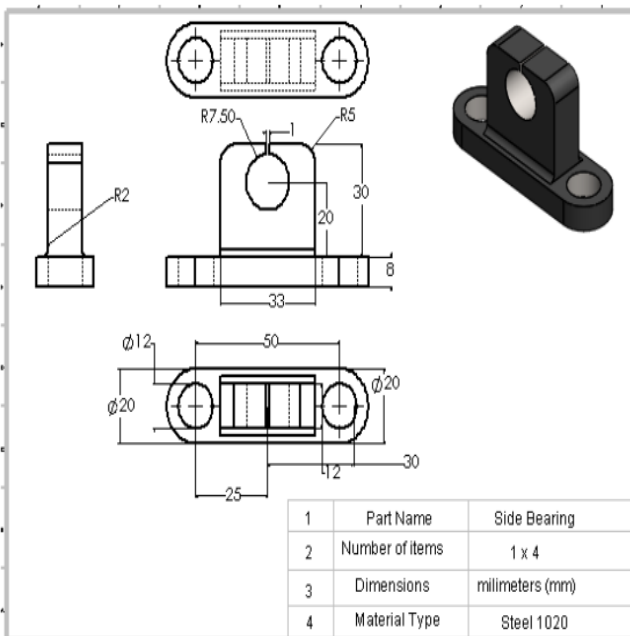

Figure 3.26: Side Bearing

3.8.14 Vertical Motor Holder

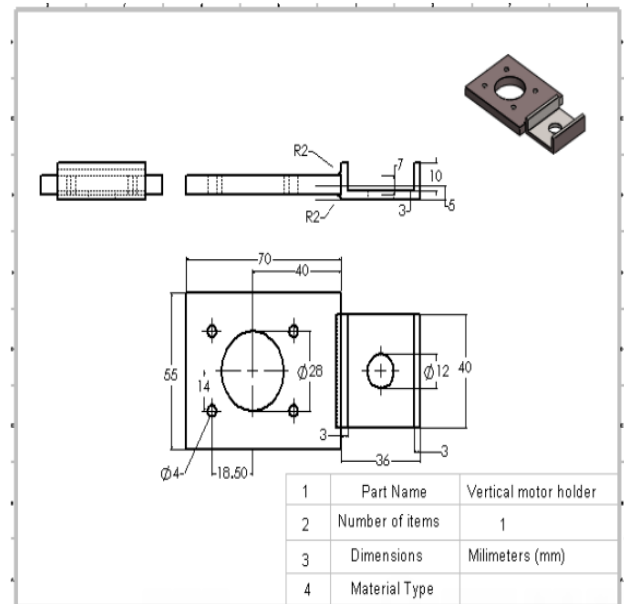

Figure 3. 12: vertical motor holder

Source: Author 2019

3.8.1.5 Isometric View

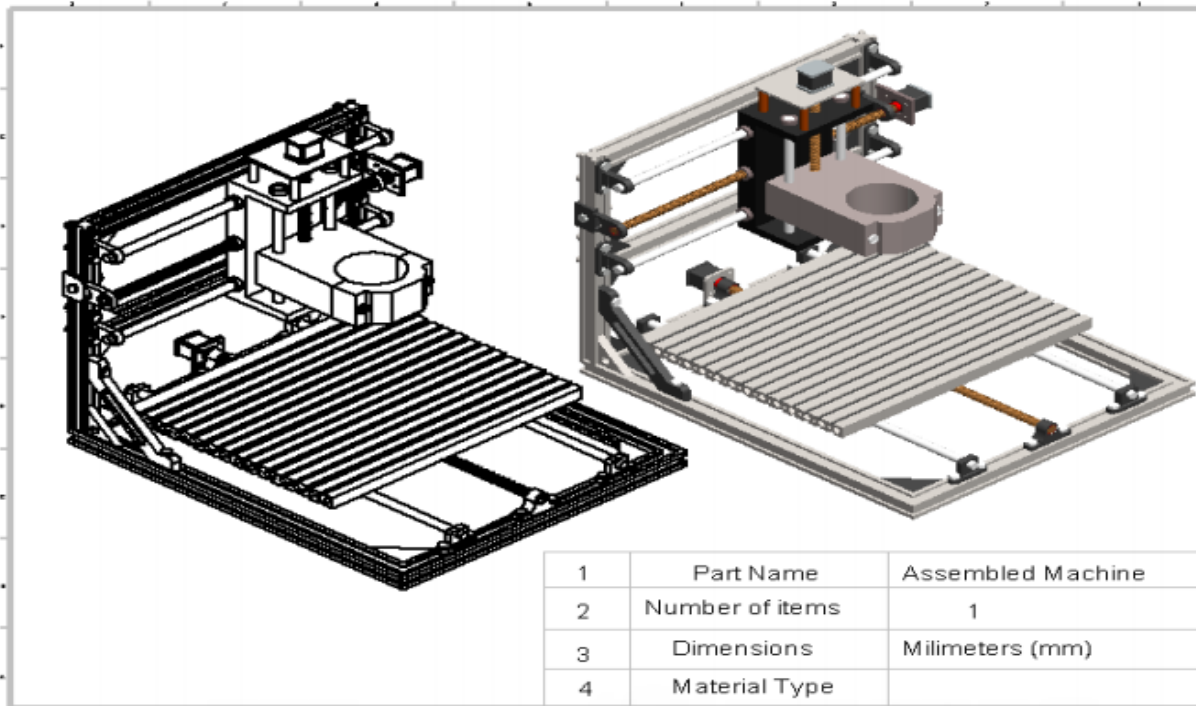

Figure 3. 13: Isometric view

Source Author 2019

4.0 RESULTS AND DISCUSSIONS

4.0 RESULTS AND DISCUSSIONS

4.1 Introduction

In this chapter, solidworks simulations was used to determine the actual results carried out on specific parts where the forces will be applied in order to determine whether the individual parts and the entire system at large will be able to withstand the forces of different magnitudes. Simulations will be carried out on stresses, deformations and at last determine the factor of safety for each part. In our simulations we used distortion energy theory to analyze the onset of failure and further determine the safety factor.

4.2 Failure definition

Permanent change in part (size, shape, material properties) that causes it to be incapable of performing its desired task. In solid works simulations, many ways are performed to account for onset of failure. Then a certain of yield strength over maximum stress limit is given in which the parts operations are safe and it is called factor of safety (FoS).

4.3 FAILURE THEORIES

4.3.1 Distortion energy theory

Yielding occurs when von mises stress meets or exceeds yield strength of the material.

4.3.2 Maximum normal stress theory

Yielding occurs when max/min normal or principal stress meets or exceeds tensile/compressive yield strength of the material.

4.3.3 Maximum shear stress (tresca criterion)

Yielding occurs when the maximum shear stress at a given point meets or exceeds $\frac{1}{2}$ of the yield strength.

4.4 Main frame simulation display

4.4.1 Mesh and Stress results

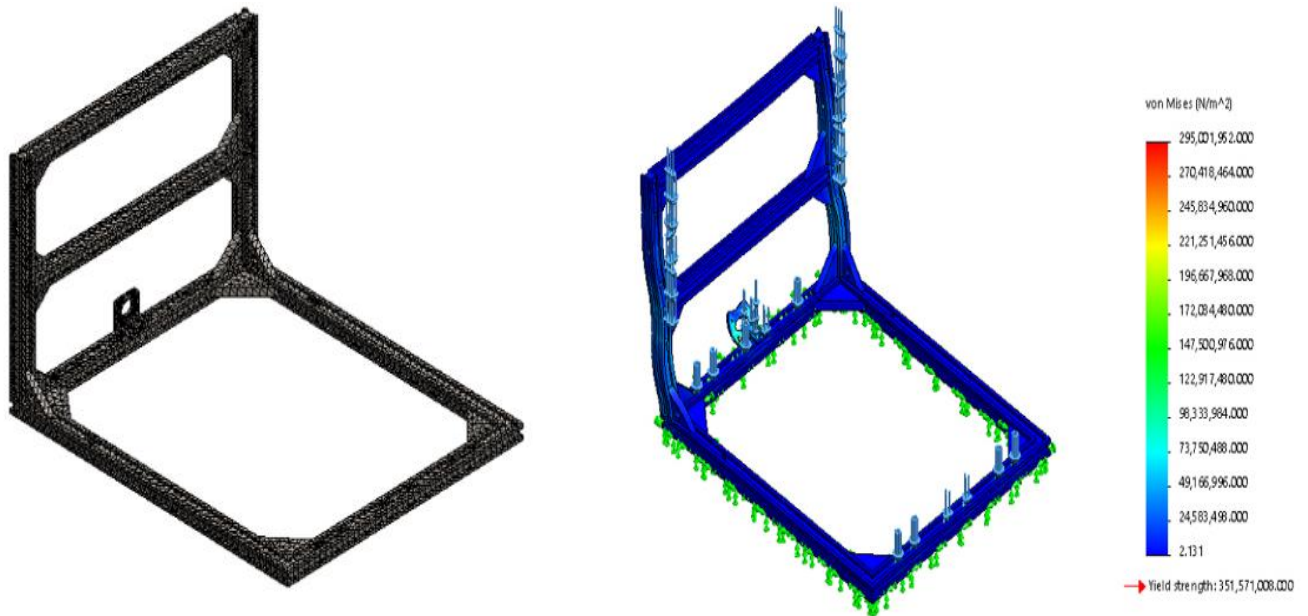

Figure 4. 1: Mesh and stress results

1.4.2 Deformation and Safety factor analysis

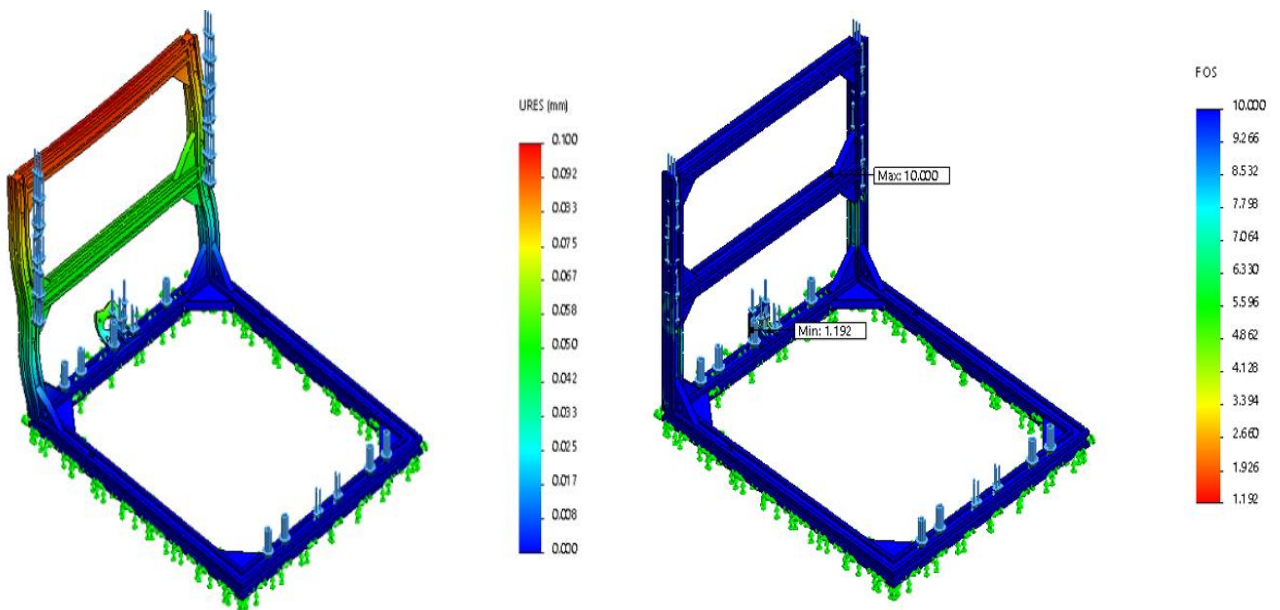

Figure 4. 2:deformation and factor of safety

4.4.3 FRAME RESULT INTERPRETATIONS (DISCUSSION)

4.4.3.1 Mesh results

Meshing is a mathematical tool of discretization. In other words, it is a process of segmenting a large material into smaller segments. This is performed in order to see how forces are distributed in each segment so that accurate results are obtained.

4.4.3.2 Element aspect ratio

Element shape can impact the accuracy of the element formulation and resultant stresses. The more an element deviates from the ideal shape the higher the potential of error. As can be seen from the meshing results in the projected figure below, the element shapes have maintained a uniform pattern in each section. This will enable the loads to be distributed evenly.

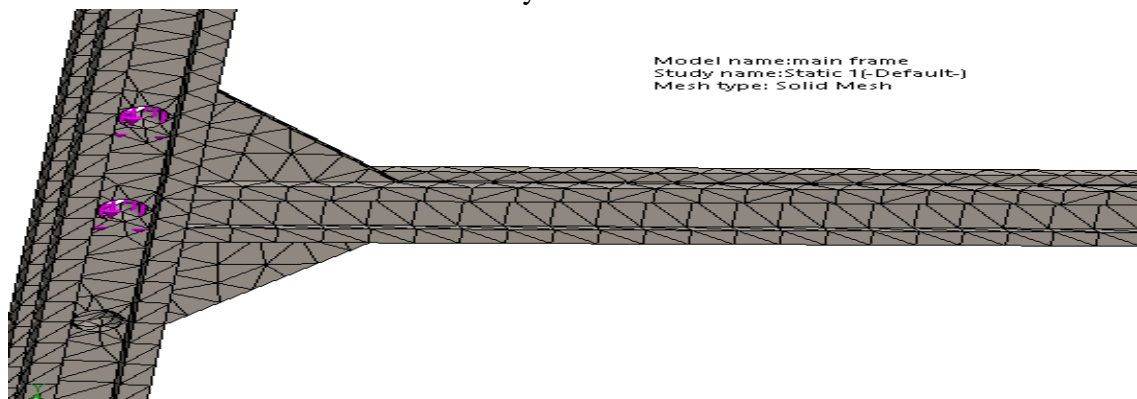

Figure 4. 3: mesh elements

Table 4. 1: Frame stress results

Name	Type	Min	Max
Stress1	VON: von Mises Stress	2.131 N/m ² Node: 41838	295,001,952.000N/m ² Node: 39682

From the figure above, the results show that when we apply a force of 10,000N, the maximum stress experienced in the frame is 295,001,952.000N/m². From the material properties steel 1020 has the yield strength of 351,571,008.000 N/m². Since the yield strength of the material is greater than the maximum stress (von mises) the frame is safe to withstand huge forces more especially when cutting materials without yielding.

Table 4. 2: Frame displacement results

Name	Type	Min	Max
Displacement1	URES: Resultant Displacement	0.000 mm Node: 1634	0.100 mm Node: 7980

Displacement analysis is all about showing how the structure flexes from the original shape under load (when forces are acting on it). As can be seen from the result table from solidworks simulations, the maximum displacement is 0.1mm, practically this is a good sign that the structure is strong since the displacement is very small and in reality its difficult to observe such a small deflection.

Table 4. 3: Frame factor of safety results

Name	Type	Min	Max
Factor of Safety1	Max von Mises Stress	1.192 Node: 39682	10.000 Node: 1

Factor of safety (FoS), is the ratio of the maximum stress that a structure part or other piece of material can withstand to the maximum stress estimated for it in the use for which it is designed. The safety factor should be above one always. When the safety factor is below one, then the material has to be either thickened, or increase the fillet radii. In our case the minimum safety factor is 1.192 and its experienced on the projected part of the frame in figure 4.2.

Theoretically, the FoS is determined as follows

$$FoS = \frac{\text{yield strength of the material}}{\text{maximum stress in the material}} = \frac{351,571,008}{295,001,952} = 1.1917 = 1.2$$

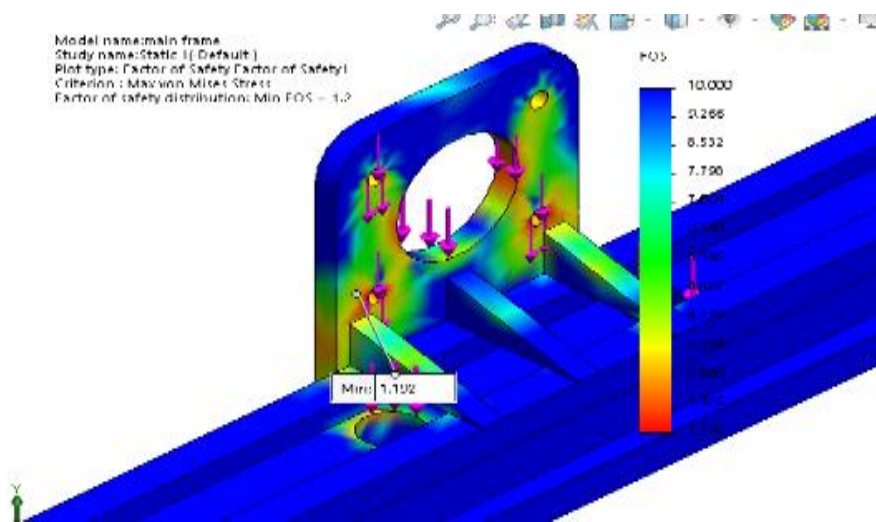

Figure 4. 4 : Factor of safety projection

4.5 Components simulations

The simulation interpretation is the same for the rest of the parts simply by observing the yield strength and the maximum von mises stress on the color codes.

4.5.1 Pallet simulation display

4.5.1.1 Mesh and Stress results

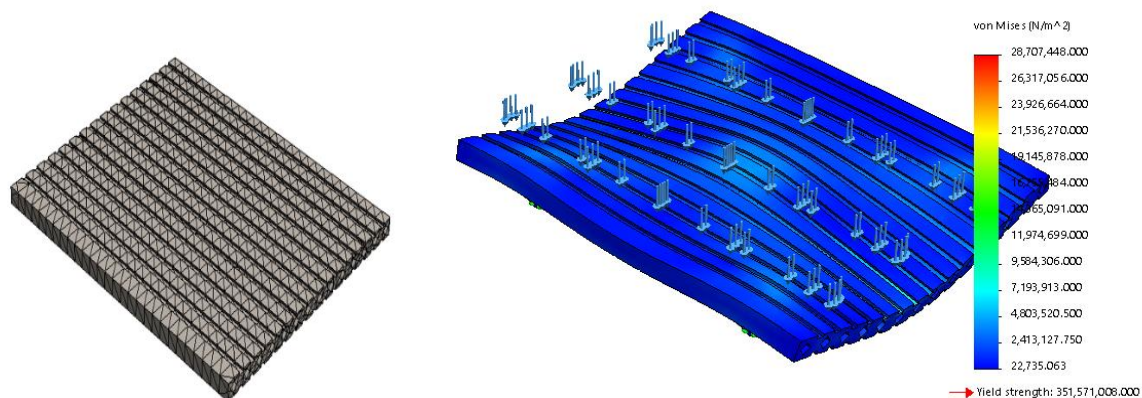

Figure 4. 5 : Mesh and stress results

4.5.1.2 Displacement and Factor of safety determination

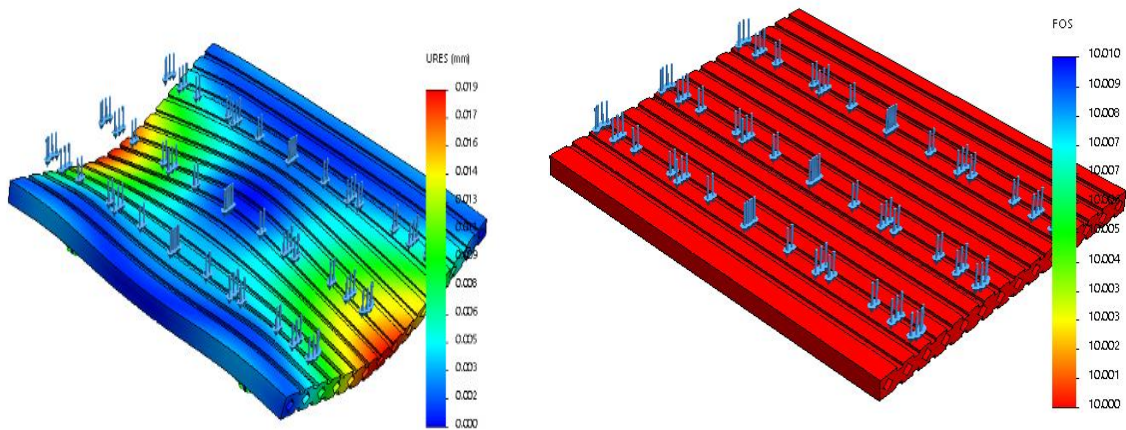

Figure 4. 6: Displacement and factor of safety determination

Table 4. 4: Pallet stress results

Name	Type	Min	Max
Stress1	VON: von Mises Stress	22,735.063 N/m ² Node: 35875	28,707,450.000N/m ² Node: 36412

Table 4. 5: Pallet deformation results

Name	Type	Min	Max
Displacement1	URES: Resultant Displacement	0.000 mm Node: 1	0.019 mm Node: 212

Table 4. 6: Pallet factor of safety

Name	Type	Min	Max
Factor of Safety1	Max von Mises Stress	10.000 Node: 1	10.000 Node: 1

4.5.3.1 Mesh and Stress results

4.5.3 Slider guide results

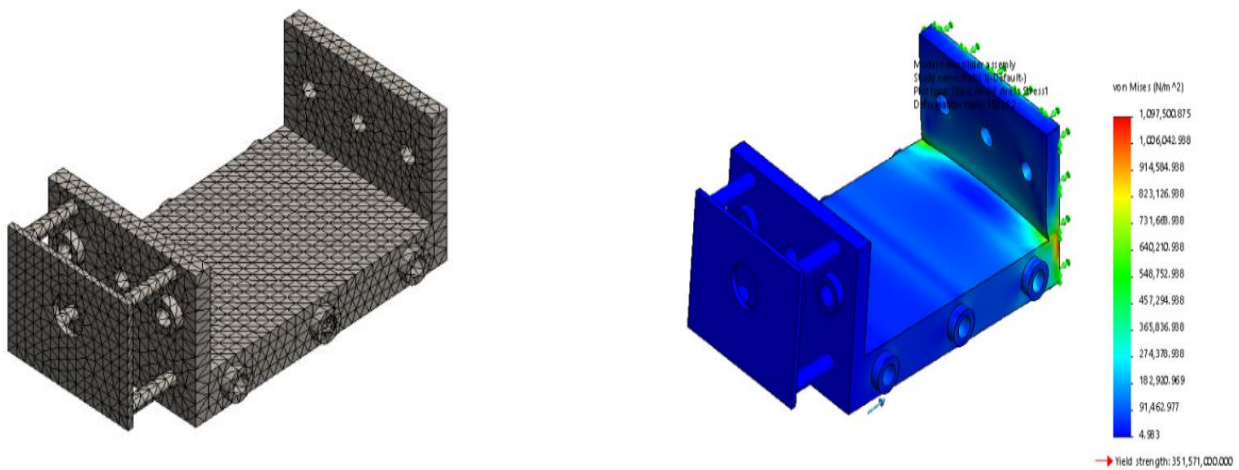

Figure 4. 7: mesh and stress results

4.5.3.2 Displacement and Factor of safety determination

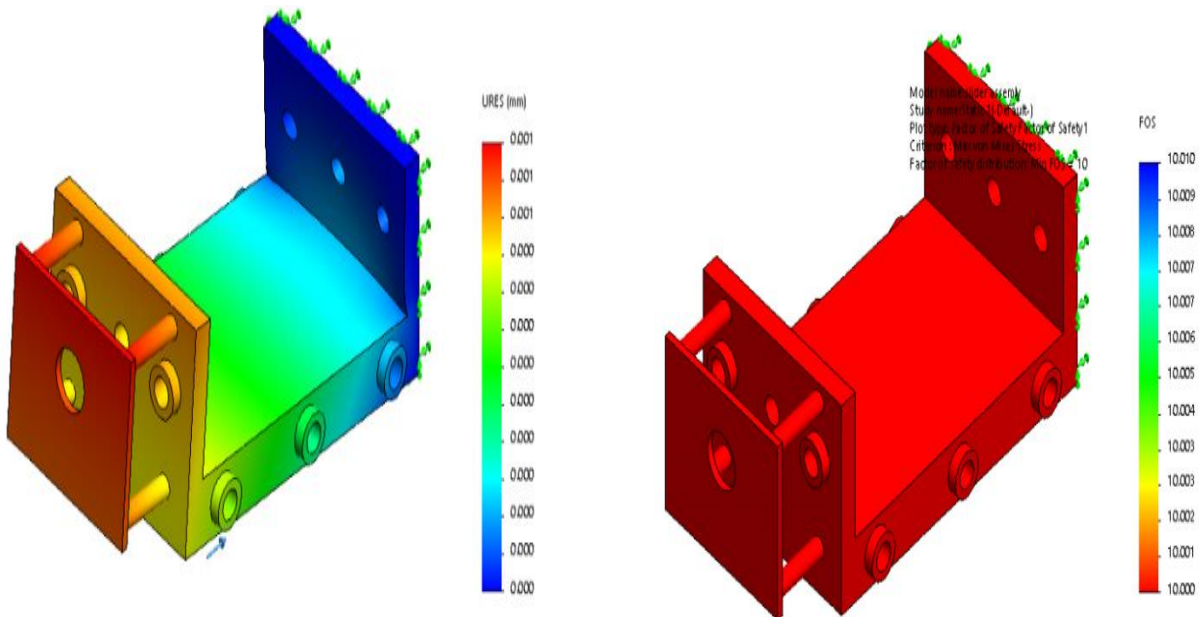

Figure 4. 8: Displacement and factor of safety determination

Table 4. 7, Slider stress results

Name	Type	Min	Max
Stress1	VON: von Mises Stress	4.983 N/m ² Node: 18517	1,097,500.875N/m ² Node: 31454

Table 4. 8, Slider displacement results

Name	Type	Min	Max
Displacement1	URES: Resultant Displacement	0.000 mm Node: 1343	0.001 mm Node: 3346

Table 4. 9, Slider factor of safety results

Name	Type	Min	Max
Factor of Safety1	Max von Mises Stress	10.000 Node: 1	10.000 Node: 1

4.5.4 Vertical bearing

4.5.4.1 Mesh and Stress simulation display

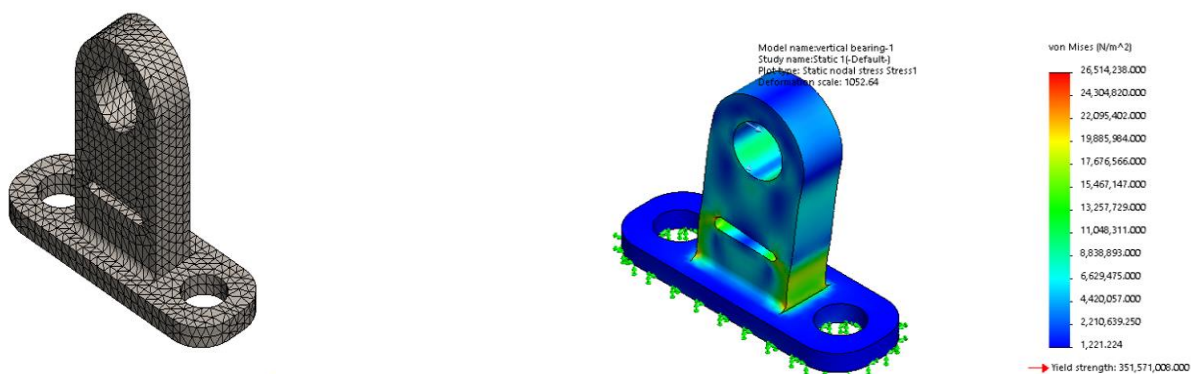

Figure 4. 9: mesh and stress results

4.5.4.2 Displacement and Factor of safety determination

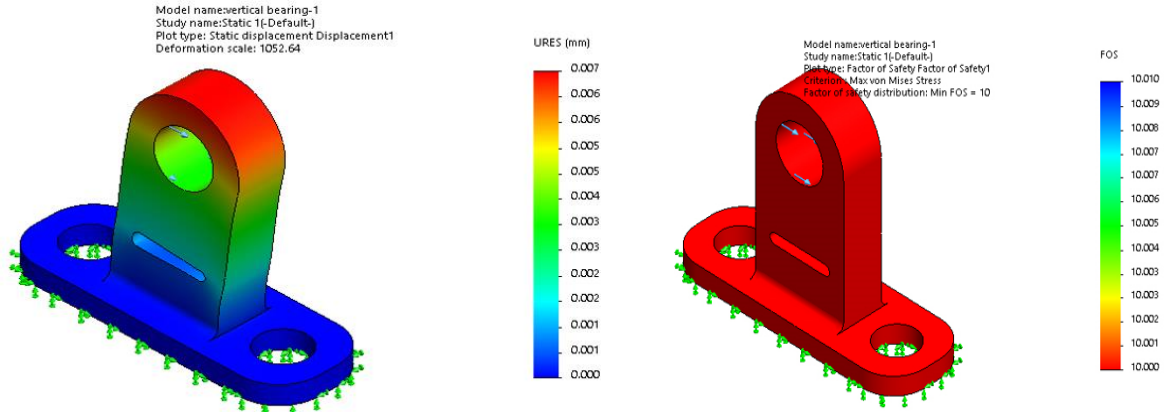

Figure 4. 10: Displacement and factor of safety determination

Table 4. 10, Vertical bearing stress results

Name	Type	Min	Max
Stress1	VON: von Mises Stress	1,221.224 N/m ² Node: 589	26,514,238.000N/m ² Node: 17862

Table 4.11 Vertical bearing displacement results

Name	Type	Min	Max
Displacement1	URES: Resultant Displacement	0.000 mm Node: 186	0.007 mm Node: 126

Table 4. 11, Vertical bearing Factor of safety results

Name	Type	Min	Max
Factor of Safety1	Max von Mises Stress	10.000 Node: 1	10.000 Node: 1

4.5.5 Motor vertical bearing results

4.5.5.1 Mesh and Stress results

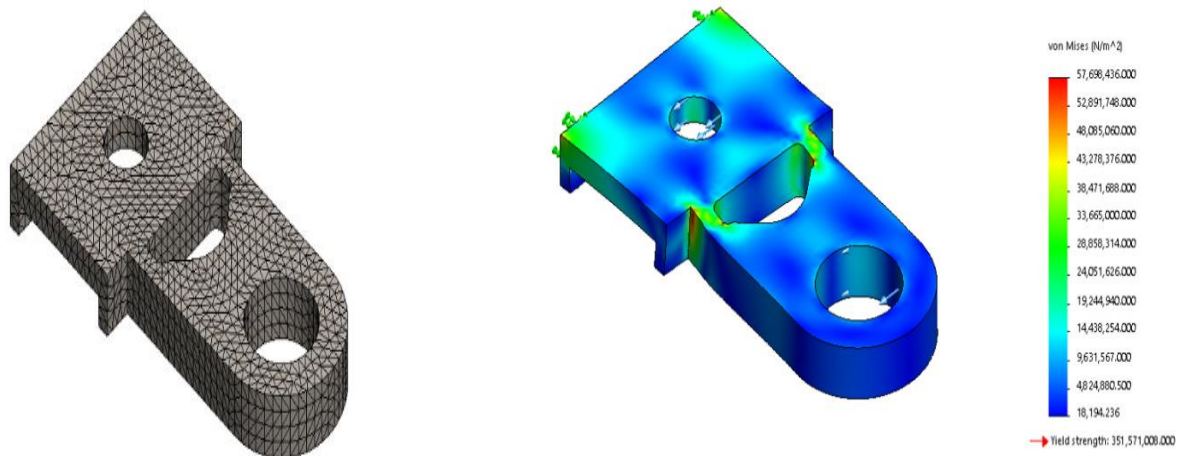

Figure 4. 11: Mesh and stress results

4.5.5.2 Displacement and Factor of safety determination

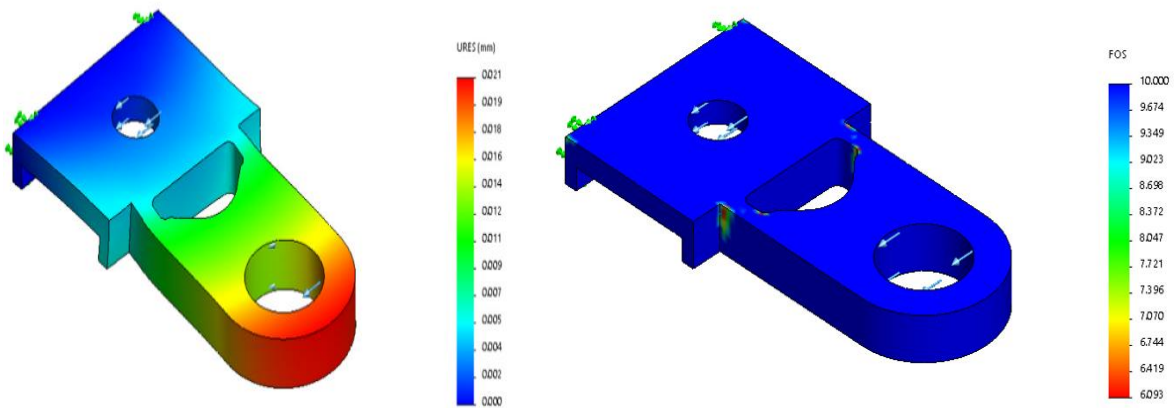

Figure 4. 12: Displacement and factor of safety determination

Table 4. 12, Motor stress results

Name	Type	Min	Max
Stress1	VON: von Mises Stress	18,194.236 N/m ² Node: 1322	57,698,436.000N/m ² Node: 20842

Table 4. 13, Motor displacement results

Name	Type	Min	Max
Displacement1	URES: Resultant Displacement	0.000 mm Node: 539	0.021 mm Node: 163

Table 4. 14, Motor factor of safety

Name	Type	Min	Max
Factor of Safety1	Max von Mises Stress	6.093 Node: 20842	10.000 Node: 1

CHAPTER 5

5.0 Introduction

This chapter will give the summary of the project and then discuss the conclusions, recommendations and future works. 5.1 Summary In this project, I got familiar with one of the famous industrial technology which is Computer Numerical Control. After a hard work for creating a working CNC prototype I have gained skills in electronics, software programming and CAD designing since I have done the work by myself. In electrical part, I have studied the stepper motor mechanism, and its control theory, I used the TB-6560 stepper motor driver. In this work, I have learned the microcontroller programming with the C language using the Arduino IDE. The results produced by my CNC are satisfactory after such a hard work; I finally got good result with a huge treasure of knowledge and skills in electronics, software programming and CAD designing. 5.2 Conclusion of the Product From this project, I learned the principle of CNC machine. I gained better understanding in the modes of operation of CNC machine. There are various types of modern CNC machines used in industry. Automatic generation of different preparatory (G codes) and miscellaneous function (M codes) is used in CNC part programming for completing a successful CNC program. Specifically, CNC milling machine works with a computer numerical control that writes and read G-code instructions to drive machine tool to fabricate components with a proper material removal rate. G-codes are commands for CNC machines to follow so that they can operate on their own without human control. Machine homing (zero set up) is very important step to obtain an accurate geometry of the work piece. From this project, I would conclude that it gives an idea for the beginners to understand on how the CNC machines work. Figure 5.1 shows the machine assembly and testing. With the increasing demand for small scale high precision parts in various industries, the

market for small scale machine tools has grown substantially. Using small machine tools to fabricate small scale parts can provide both flexibility and efficiency in manufacturing approaches and reduce capital cost, which is beneficial for small business owners and hobbyists. In this thesis, a small scale three axis CNC milling machine is designed and analyzed under very limited budget.



Figure 5. 1: Machine Assembly and Testing
Source: Author 2019

With the rising demand of small parts and operations, number of small-scale automated machines like CNCs and 3D printers came into the top fabricating work for the industries. The priorities are being given to fabricate those machines in affordable price and size. Here in this paper it has been designed and tried to build a CNC with compatible to 3D printer which is very simple and affordable.

5.3 Discussion and Future Work

Working on this individual project was interesting though challenging as it integrated the application of hardware and software design principles. It has been planned to develop the machine to very useful 3D printer with more modification on the structure, framework and speed of printing and with some other parameters. It is also taken into account to make it much limited in budget and easily workable. The required power should be minimized somehow. As further work, I propose to use servo or DC motors instead of stepper motors that provide more precision. Also, for safe work, it is better to make limit switches at the end of each axis and try to use some sort of sophisticated spindle.

5.4 Recommendations

The following are the recommendations hereby proposed;

- When making the printer, precision in the mark out is cardinal and this is ensured by following the correct use of tools and equipment, there should be no short cuts in marking out. And if that is not carefully adhered to then the printer will be inaccurate in its operations.
- 77 · There should be trainings to educate people in electrical installations for the electronic wiring, programming and CAD designing. When people are skilled in electrical installation or wiring then the issues of maintenance would not be a problem.
- There should be much advocacy on the promotion of CAD packages in the Zambian school curriculum, so much that it is easily embraced at an early stage by scholars in the Design and Technology domain.
- The printer extruder nozzle needs to be multi-color to accommodate variety filament colors and sizes so that there is beauty in finished printed object.

ACKNOWLEDGEMENT

First and foremost, I would to thank the Almighty God for keeping me healthy during the whole period of my studies. Secondly, I owe a deep and sincere debt of gratitude to my supervisor, Dr. Oliver Silumbe for his continuous and constructive support even up to the time when I nearly quitted. His valuable suggestions and generous guidance enriched this study throughout every stage of it. I wish also to express my gratitude to Mr Ngosa Mutale, a Copperbelt University Students for according me chance to go through my electronic work of my research. I am indebted to many people for helping me produce the final project. I will be insincere if I do not recognize contributions made by the following people; Mr. Gift Banda for tips on welding, Mr. Mainza (lecturer at ICU) for providing tips on how to write an engineering thesis , Mr. Silumesi for tinting and spraying of the machine and Mr. Lupupa Clement (Fellow ICU Student – Kitwe) for providing me free transport from his residence place south-west of Kitwe to heavy industrial area, north of Kitwe in search for a company that use computer numerical control machine. Special gratitude goes to my able supervisor Mr Moses Kaleji, Love Musonda, Abigail Musonda, Blessings Musonda and Joshua for the patience when I worked long hours and away from them both during working days and weekends. To you all, I salute you for your loving and encouraging words.

REFERENCES

- [1] Anon., 2014. *CNC Made Easy*. [Online] Available at: <http://diymachining.com/grbl-settings-101-a-how-to-guide/> [Accessed 27 September 2019].
- [2] Anon., 2015. *HPLC Method Development*. [Online] Available at: <https://www.researchgate.net/figure/Process-flow-sheet-showing-the-situation-of-the-collimator> [Accessed 02 August 2019].
- [3] Anon., 2016. Block Diagram of the complete operation. *International Journal of Innovative Research in Science*, 5(9).
- [4] Anon., 2016. *Image Credit: Andrey Armyagov*. [Online] Available at: <https://www.thomasnet.com/articles/custom-manufacturing-fabricating/understanding-cnc-milling/> [Accessed 10 August 2019].
- [5] Anon., 2016. *ISL Products*. [Online] Available at: www.islproducts.com/designnote [Accessed 20 August 2019].
- [6] Anon., 2017. *Autodesk Knowledge Network*. [Online] Available at: <https://knowledge.autodesk.com/support/powermill/learn-explore/caas/CloudHelp/cloudhelp/2018/ENU/PWRM-ReferenceHelp/files/GUID-47F9A737-04F5-42D4-B41D-A9AEC1B331CA-htm.html> [Accessed 15 August 2019].
- [7] Anon., 2018. *Mech4study*. [Online] Available at: <https://www.mech4study.com/2016/05/milling-machine-operation.html> [Accessed 20 August 2019].
- [8] Anon., 2019. *Fifth Metal Industrial Co., LTD.*. [Online], Available at: <https://www.fmcncmachining.com/info/cnc-milling-operations-> [Accessed 02 August 2019].
- [9] Anon., 2019. *IGOLDENCNC*. [Online] Available at: <https://www.igoldencnc.com/multi-head-cnc-router-wood-carving-machine.html> [Accessed 25 August 2019].
- [10] Anon., 2019. *JAMECO WORKSHOP*. [Online] Available at: <https://www.jameco.com/Jameco/workshop/circuitnotes/CN-arduino-uno.html> [Accessed 26 August 2019].
- [11] Anon., n.d. *CNC projects*. [Online] Available at: <https://store.designandmake.com/shop/product/18600> [Accessed 8 september 2019].
- [12] Anon., n.d. *Saravana Electronics*. [Online] Available at: <http://www.alselectro.com/stepper-drive-3amp-toshiba-tb6560-.html> [Accessed 20 August 2019].
- [13] Belhocine, A. M. & B., 2016. *Implementation of Low Cost Three Axis CNC Machine with Network Control*, Boumerdes: s.n.
- [14] Development, T. A. I. F. P., 1988. *Lathe Operations*. 8 Ed. S.L.:The Army Institute For Professional Development.
- [15] Electronics, J., 2019. *Arduino Uno Pinout Diagram*. <https://www.jameco.com/Jameco/workshop/circuitnotes/CN-arduino-uno.html>.
- [16] Haji, S. A. M. B. D., 2013. *Design And Fabricate Of Portable Cnc Milling Machine*, Universiti Malaysia Pahang: Siti Aina Mardhia Binti Dol Haji.
- [17] Hauzkha, J. S. &., 9998. *Production Technology. The Gate Coach All Rights Reserved 28, JiaSarai N.Delhi-16, VOLUME 1(1), pp. 2 - 16.*
- [18] *History of CNC machining*, s.l.: s.n. (2012) <http://sino-mold-tooling.com/blog/history-of-cnc-machining/>,
- [19] The Robinson library. (2019) <http://www.robinsonlibrary.com/technology/manufactures/textile/whitney.htm>,

- [20] *Lathe Operations* (1988), s.l.: the army institute for professional development. <http://www.cascom.army.mil/ordnance/>,
- [21] *AISI 1020 Low Carbon/Low Tensile Steel*, s.l.: AZON (2012) <https://www.azom.com/article.aspx?ArticleID=6114,..>
- [22] *Arduino Uno Pinout Diagram*, s.l.: s.n, 2019. <https://www.jameco.com/Jameco/worksop/circuitnotes/CN-arduino-uno.html>,
- [23] Thomas Industry ,2016. *Understanding CNC Milling*, s.l.: Update. <https://www.thomasnet.com/articles/custom-manufacturing-fabricating/understanding-cnc-milling/>,
- [24] Jianbin, S. J. & X., 2018. Comparison of Different Types of 3D Printing technologies. *International Journal of Scientific and Research Publications*, 8(4), pp. 2 - 9.
- [25] Kelly, P. H.-D. & J. F., 2009. *Build Your Own CNC machine*. New York: Paul Manning.
- [26] Malama, T., 2007. *Tool Design For The Production Of A Collimator On A 3-Axes Vertical Milling Centre*, s.l.: s.n.
- [27] Rahman, M. A. B. A., 2013. *3 Axis Cnc Machine Controllers*, Universiti Malaysia Pahang: Mohd Azri Bin Abdul Rahman.
- [28] Resource, D. W., 2019. What's the difference between contouring and point-to-point motion?. <https://www.motioncontroltips.com/faq-whats-difference-contouring-point-point-motion/>.
- [29] Sriranga V Deshpande1, P. U. K. N. K. D. D. V. K. D. K. S. B., 2018. Design and fabrication of 3-axis CNC Milling machine. *International Journal of Engineering Research and General Science*, 6(4), pp. 34 - 38.
- [30] Thapa, S., 2014. *Structural Design of a 3-axis CNC machine tool for wood carving*, Patiala: s.n.