

---

# Design and Development of a Manually Operated Cooker Stumping Press: A Quest To Revamp Manufacturing In Zambia

(Conference ID: CFP/118/2017)

Emmanuel Zulu  
School of Engineering  
Information and Communications University  
Lusaka, Zambia  
[zulusindikani@gmail.com](mailto:zulusindikani@gmail.com) quest

Dr. Oliver Silumbe  
School of Engineering  
Information and Communications University  
Lusaka, Zambia  
[Osilumbe05@gmail.com](mailto:Osilumbe05@gmail.com)

## **Abstract**

*Sheet metal forming is the most utilized method of manufacturing engineering components. With the closure of companies in Zambia soon after liberalizing its economy, little has been done in engineering manufacturing. Most goods are imported despite having abundant mineral resources which are exported without value addition. The primary goal of the study was to design and develop a Manually Operated Stumping Press for producing single plate cooker covers. The designed product was conceptualized after seeing households still using charcoal/firewood for cooking despite being connected to the national electricity grid. The machine uses simple technologies, the critical part being die production using sand casting, a method rarely practiced in Zambia. Pressing machines exist in different working principles and use differently shaped dies to produce components. Modern machines are highly computerized and could not be adapted in*

*this design. The design considered the fact that in every mechanical process, certain defects exist due to the natural resistance of the material. The machine designed will help entrepreneurs produce identical parts quickly unlike producing them the blacksmith way. This project works on provision of forces manually with help of gravity, forcing dies together to form sheet metal. Gravity dependent presses are effective though the operator risks injuries when loading and offloading workpieces. Stress, strain and shear forces were identified and calculations done to determine parts sizes. With this product operationalized households will be encouraged to use clean and quick methods of cooking especially with the 'buy Zambian' campaign already advocated for.*

**Key Words:** *Design and development; manufacturing; manually operated; sheet metal forming; springback; forces; casting.*

## 1.0. Introduction and background

### 1.1. Introduction

In ancient times, metal was shaped manually using big hammers. A helper was required to swing the sledge hammer while the smith positioned the work piece. Thereafter steam power and wind mills were utilized to operate the large hammers. Pressing machines date from 1900s when the French oil mill machinery was founded. Due to electrification, most of the power presses used electrical power and have continuously improved, utilizing hydraulics and are programmable.

### 1.2. Background

Manufacturing industry is critical to any country's development. Zambia lost its manufacturing capability after liberalization of the economy and this affected negatively its earnings and thus, its development. The absence of manufacturing (except in detergents, confectionery, brewery, milling, etc.) and the reliance on imported goods has led to high prices of electrical appliances such as cookers. For instance, four plate cookers sell at as much as K18 000 (USD 1800). Most households are unable to afford these items and thus rely on charcoal or firewood for their cooking which are difficult to ignite (especially during the rainy season) and produce smoke that dirty kitchen walls and ceilings. Children abscond from school in order to fetch firewood when it runs out. Some households use paraffin stoves (in some cases diesel) for this purpose, and the food cooked smells fuel.

The study was carried out in Luanshya district located on the Copperbelt province of Zambia. Despite being a mining town, most people are unemployed due to retrenchments from the struggling mines and practice peasantry farming

while others are in charcoal burning as a source of living.

This machine was made with the view to produce cheaper Zambian made single plate cookers. This is with due consideration that industrial stamping machines are too expensive to be purchased by local entrepreneurs. With this product available, it is hoped that eventually several hectares of forests will be saved from destruction.

This project involved the designing and making of a product to produce two parts (cover and base) of a single plate cooker from 0.8 - 2 mm sheet metals. The project required the use of a jack, levers, and dies and is manually operated. Proper lever arm and jack assembly heights were necessary for efficient operation of the machine to eliminate discomfort caused by over bending or overreaching.

## 2.0. Materials / Methods / The Design

### 2.1. Materials

Innovation is important for a successful and sustainable product design. This is a design approach which takes into consideration all the phases of the product's life-cycle, from concept development to retirement, analyzing and harmonizing determining factors such as quality, cost, production feasibility, requirements of use, servicing and, indeed, environmental aspects. Prabhakar, Haneef & Ahmed (2013) advise that when selecting materials, the following be taken into consideration; constraints of shape and dimension, required performance, manufacturability, energy consumption and cost.

### 2.2. Methods

The methods used in this design are in three phases; the first being the collection of households heat source needs by observation. The second

phase was the design of an appropriate machine to produce parts of a single plate cooker for their use in order to meet their needs, and the final phase was to assess the performance of the machine and determining whether produced parts could solve the problem.

Majority of the households in the site under study lamented of the high costs charged by local business people who sell charcoal. This indicates great need for affordable cooking equipment as families are forced to dig deep into their pockets to facilitate payment of equipment or purchase bags of charcoal which do not even last long. Some use alternatives such as firewood, or maize shelled cobs or offcuts picked from near-by make shift sawmills as a fall back plan if all means to cook fail.

Additionally households also complained of the time spent to light it and the smoke which such equipment produce. They suggested that if a cheaper solution would be availed to them to solve cooking problems with minimal smoke, then such a technique would be warmly welcome and embraced by all.

Determination of cooking speed is vital. Comparison was made on the time taken to light a fire (charcoal or firewood) and cook a meal for six; and switch on a stove and cook a meal for six. It was discovered that it takes 10 – 15 minutes to light the fire alone while when using a stove during this period meal preparation would have advanced. Cooking on the stove is neater and the food does not smell smoke and is done inside the house without depositing soot onto walls and ceiling.

Sketches and engineering drawings were done using computer drawing software which included Google Sketch Up, AutoCAD and SolidWorks.

## 2.3.The design

### 2.3.1. Pressing techniques

The forming of the sheet metals required production of moulds /dies (male and female). One alternative of moving the mould was to use gravity. Gravity dependent presses are simple and utilize the natural phenomenon of gravity to press material. A heavy mould is raised to some distance directly above another, on which the material to be pressed and released so that it lands with a great force and shape the material (though the operator risks injury especially when loading and offloading the work piece).

Engineers use levers to magnify a force applied to an object. The mechanical advantage of these machines helps determine their ability to make work easier and faster. It is from this explained advantage that the lever system was used in the project to transfer forces to the moulds that form the surface of the single plate cooker cover.

### 2.3.2. Sheet metal forming

Sheet metal parts are light weight and versatile shapes can be produced due to good strength and formability characteristics especially when low-carbon steel is used. Forming is the most important manufacturing process for converting the geometry to the required shape. “Important forming processes are forging, extrusion, rolling and bending” (Prabhakar et al, 2013). These methods are used on industrial products depending on the shape and bending dies. Yoshida, Isogai, Sato & Hashimoto, (2013) write that in every mechanical process certain defects exist due to the natural resistance of the material when forging it. One type of these defects is springback. “Springback is mainly due to Bauchigner’s effect which allows the material to follow different paths during loading and unloading cycles” (Yoshida, et al,

2013). “This happens because metal wants to decompose on the inside radius and return to its flat shape on the same radius” (Sharad & Nandedkar nd). Adequate measures were taken to cope with increased recovery of sheets. A countermeasure is to design forming dies that anticipated springback compensation, Ashby & Jones (2007) advise. Alternatively, Giudice, La Rosa & Risitano, (2004) suggest over bending and using thin sheets as simplest ways of combating springback problem.

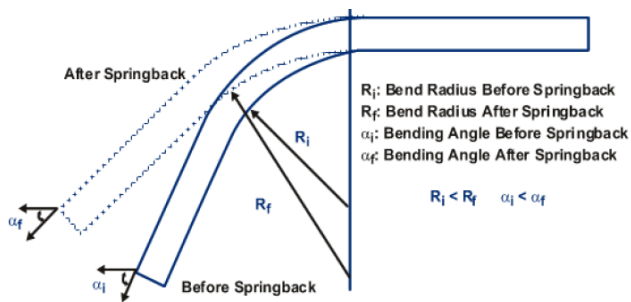

**Figure 1: Springback illustration**

### 2.3.3. Theoretical framework

Local materials were used for the machine and its cost is projected to be low and affordable as a result. For efficient performance, 2 mm thick aluminum or 0.6 mm low carbon steel sheets were used in order to take care of springback. Some factors such as mould design, tensile forces, compressive forces, shear forces and bending moments were taken into consideration. For instance, the central bar is under compression stress.

Assuming that there is no bending moments in the top blocker,

$$\text{Compression stress} = \frac{F}{A} \quad (1)$$

Where F is force applied and A is unit surface area of the bar. But area of a round bar is given by;

$$A = \frac{\pi d^2}{4} \quad (2)$$

Young modulus (E) of a material is given by the ratio between stress and strain, thus;

$$E = \frac{\text{Stress}}{\text{Strain}} \quad E = \frac{\sigma}{\tau} \quad (3)$$

Since the young modulus of mild steel is given, then strain ( $\tau$ ) will be;

$$\tau = \frac{\sigma}{E} \quad \text{But} \quad \frac{\delta l}{L} = \frac{\sigma}{E} \quad (4)$$

Where L is the length of the piece and  $\delta l$  is the change in length of material under stress

In the lever arm we expect some shear forces on the M16 bolts. Shear force is a force applied sideways on a material



**Figure 2: Load carrying pin**

Shear stress is a force per unit area carrying the load. Shear stress  $\tau = \frac{F}{A}$

Shear strain ( $\gamma$ ) is a force that causes material to deform to the height. It is the ratio of the distance deformed to the height  $\frac{x}{L}$  thus the relationship gives;

$$\frac{F}{A} = \frac{x}{L} = \frac{FL}{Ax} = \frac{\tau}{\gamma} \quad (5)$$

$$\text{Modulus of rigidity} \quad G = \frac{\tau}{\gamma} \quad (6)$$

### 2.3.4. Design working principle

The uniqueness of this design is its working principle of stamping and bending sheet metal.

Two systems exist for a full operation. The first one involves a hydraulic jack which provides pressure to the dies for shaping the surface of the plate. As the jack is operated, two dies press against each other with the blank in between, thus forming the designed shape onto the sheet metal. The second operation involves the lever system pivoted at one end, with rods connected to the lever and to the collar; the collar is lifted when other end of the lever is lifted. When the lever end is pressed down, the collar is also pressed down and sheet metal is folded. The pressing part of the lever is made longer to provide mechanical advantage. The collar opening is tapered for easy shaping as shown in figure 2 below.

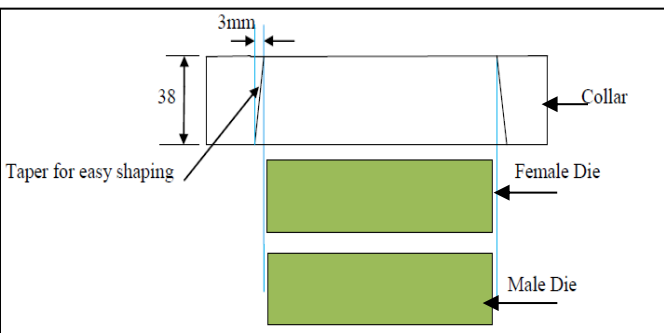

Figure 3: Collar taper

## 2.4.Components of the design

### 2.4.1. Labelled parts

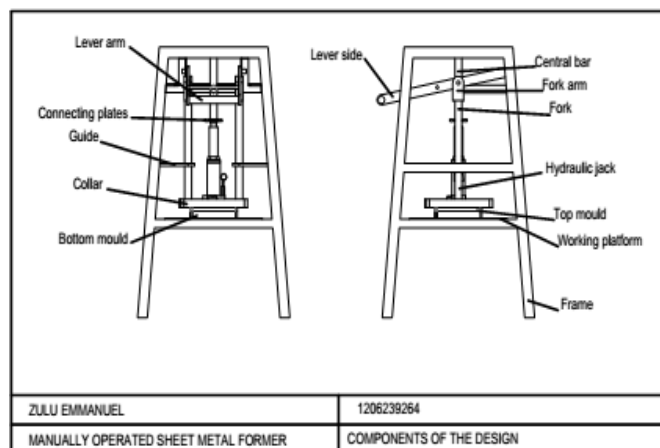

Figure 4: Parts of the design

### 2.4.2. Die sizes

The pattern was designed to ensure a perfect replication of the original design.

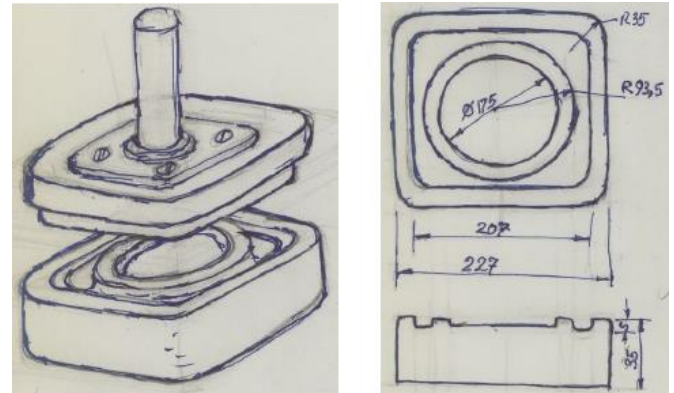

Figure 5: Die design (Male and Female dies)

### 2.4.3. Functioning parts

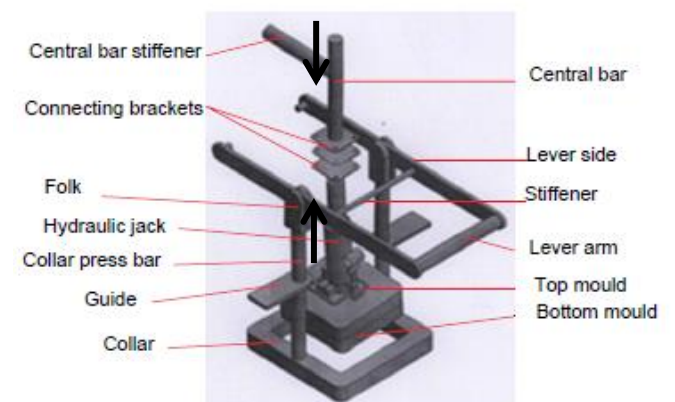

Figure 6: Functioning parts

## 2.5. Design calculations

When a body is acted upon by some load, it undergoes deformation which increases gradually. During deformation of the material, the body



resists this tendency and this internal resistance is called stress. We expect some stress in the central bar as the jack is raised.

$$\text{Stress} = \frac{\text{load}}{\text{Material cross section}} = \frac{P}{A}$$

Since the load is a 5 ton jack and cross section of central bar is diameter 32mm, then;

$$\text{Compression stress} = \frac{F}{A}$$

Where F is force applied and A is unit surface area of the bar obtained by;

$$A = \pi r^2, \text{ when radius is given}$$

$$\text{Thus, } A = 3.142 (16^2) = 804.25 \text{ mm}^2$$

$$P = 5 \text{ ton} = 50\,000 \text{ N} \quad \text{or } 50 \text{ KN}$$

$$\text{Therefore Stress} = \frac{50000}{804.25} = 62.2 \text{ N/mm}^2$$

$$\text{or } \frac{50 \text{ KN}}{8.0425 \times 10^{-4} \text{ m}^2} = 62.2 \text{ KN/m}^2$$

Young modulus (E)

$$E = \frac{\text{Stress}}{\text{Strain}} \quad E = \frac{\sigma}{\tau}$$

Since the young modulus of mild steel is given as 207 GPa (i.e. 207000MPa) or 207 000 000 000 N/m<sup>2</sup>, then strain will be;

$$\tau = \frac{\sigma}{E} \quad \tau = \frac{62.2 \text{ KN/m}^2}{207 \text{ GPa}} \quad \tau = \frac{62.2 \text{ KN/m}^2}{207 \times 10^9 \text{ N/m}^2}$$

$$\tau = \frac{62200 \text{ N/m}^2}{207 \times 10^9 \text{ N/m}^2} = 3.005 \times 10^{-7}$$

$$= 0.0000003005$$

Change in length of the central bar will be:

$$\frac{\delta l}{L} = \frac{\sigma}{E}$$

Where L is the length of the piece and  $\delta l$  is the change in length of material under stress

Making  $\delta l$  subject of the formula;

$$\delta l \times E = \sigma \times L \quad = \quad \delta l = \sigma \times L / E$$

Where length of bar is 260 mm (0.26 m)

$$\begin{aligned} \delta l &= \frac{62200 \text{ N/m}^2 \times 0.26 \text{ m}}{207\,000\,000\,000 \text{ N/m}^2} \\ &= \frac{16\,172 \text{ N/m}^2 \text{ m}}{207\,000\,000\,000 \text{ N/m}^2} = 7.81 \times 10^{-8} \text{ m} \end{aligned}$$

Therefore the bar will change in length by

$$7.81 \times 10^{-8} \text{ m} \quad \text{i.e. } (7.81 \times 10^{-5} \text{ mm})$$

This is 0.0000781 mm which is very negligible

$$\text{Shear stress on the diameter 16 bolt; } \tau = \frac{F}{A}$$

Where total force will be: force by operator + force of collar + force of folks + force of lever sides + force of lever arm + force of stretcher.

If the operator weighs 75 Kg and presses the lever down, he probably will use  $\frac{3}{4}$  of his weight as he will be standing on the ground. Therefore force by operator will be;  $\frac{3}{4}$  of  $75 \times 9.81 = 551.8 \text{ N}$  (1)

Volume of the entire lever / collar system is;

$$\begin{aligned} &(300 \times 300 \times 40) - (220 \times 220 \times 40) \text{ (collar)} + \\ &2(3.142 \times 16^2 \times 340) + 4(100 \times 50 \times 10) + 2(50 \times 15 \times 10) + 2(615 \times 40 \times 10) + (3.142 \times 15^2 \times 250) + \\ &(3.142 \times 6^2 \times 250) + 2 \times (3.142 \times 7^2 \times 54.8) + \\ &0.5(14 \times 12.13) \times 6 \times 19.6 \times 2 = \end{aligned}$$

$$1\,664\,000 + 546\,959.36 + 200\,000 + 15\,000 + 492\,000 + 176\,737.5 + 28\,278 + 36\,844.63 = 3\,159\,819.49 \text{ mm}^3$$

This means that the total volume is

$$3\,159\,819.49 \text{ mm}^3 \quad \text{i.e. } 3\,159.82 \text{ cm}^3$$

Density of Mild steel is given as 7.85 g/cm<sup>3</sup>

Therefore, Mass = volume x density

$$\text{Mass} = 3\,159.82 \text{ cm}^3 \times 7.85 \text{ g/cm}^3$$

$$= 24\,804.59 \text{ g} = 24.8 \text{ kg}$$

The force exerted by this sub assembly is;

$$24.8 \text{ kg} \times 9.81 \text{ m/s}^2 = 243.29 \text{ Kg.m/s}^2$$

$$= 243.29 \text{ N} = 243.3 \text{ N} \quad (2)$$

Combining (1) and (2) we get;

$$551.8 + 243.3 = 795.1 \text{ N} = 795 \text{ N}$$

This means that a total of 795 N will be exerted on the metal sheet in a bid to shape it.

Experiment was conducted to determine the depth of displacement for the collar.

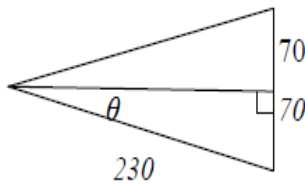
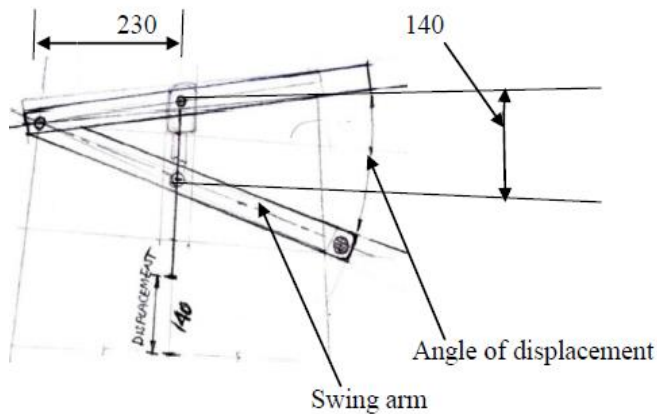

$$70 / 230 = \sin \theta = 17.7^\circ$$

$$2 \times 17.7 = 35.4^\circ$$

### 3.0. Results

For a swing of  $35.4^\circ$  the lever was able to make a vertical displacement of 140 mm, a distance sufficient enough for the operator of the machine to place material being worked on and removing formed component. A 5 ton hydraulic jack did not perform according to earlier assumption that it would successfully form 0.8 - 2 mm thick sheet metal. This is because the galvanized sheet used, though thinner than the 0.8 - 2 mm sheet, presented stronger spring-back which resulted in two 5 ton hydraulic jacks being destroyed.

The 640mm long pressing lever was not long enough to provide sufficient mechanical advantage

to press the collar down and hence did not efficiently shape sides of the component.

### 4.0. Discussion

The lever could have been made much longer, to a minimum of 1000 mm to enable easy leverage.

For the purpose of the entrepreneur, the machine will be helpful in producing product parts which are identical both in dimensions and shape. The time needed to produce the parts would be reduced, and the consistency of the produced shape would be better than those that could be produced using the blacksmith way.

The product was well constructed. It was rigid, stable and ergonomically suitable for the operator. The top mould / jack sub-assembly needed a guide to help with a perfect alignment with the bottom mould.

The machine was first tested on 6mm cardboard and it formed cardboard successfully, as shown below.



6mm thick carton box card shaped successfully

When tested with 4mm aluminum sheet, only the top surface shaped successfully but failed to bend the sides completely.



When the test was done on 0.4 mm galvanized sheet the shape formed well on the face and reasonably well on the sides especially when corners were cut as shown in diagram below

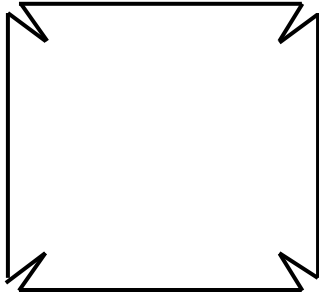

The machine was soundly fabricated as it was rigid and stable with its height suitable for the standing operator. The choice and application of the finish were skillfully done. The combined weight of the collar and lever arm was small and meant that the operator had to use more effort to successfully bend the metal sheet. It was sometimes difficult to align male and female formers when sheet metal was in place. This was because the hydraulic jack could rotate carrying with it the top mould whilst the bottom mould was fixed.

## 5.0. Conclusion

Continuous improvement unceasingly strives to improve the performance of production and service firms. "Learning cycle theory states that each time management takes an action to improve the process, observes the results thereby learns how to improve the process further over time" (Zangwill, & Kantor, 1998).

If the project was to be made again, the following modifications would be considered:

1. Make the upper mould thicker (from the current 35mm to around 70 mm), thus doubling the weight of the mould and improve the punching activity.
2. Make the bottom mould thicker to 50mm in order to obtain a deeper formed piece.
3. Make collar thicker and wider to increase its weight to enable it fold sheet metal easily.
4. Make lever arms longer to increase the mechanical advantage of the system. Make its sides 60 x 20 (from current 40 x 10) to increase weight.
5. Make engraving of the die faces deeper from the current 6 to 10 mm so that shape comes out distinctly
6. Provide a guide to upper die to make it remain aligned all the time.
7. Replace a 5 tons jack with 10 tons jack to increase the forming force.
8. Warm sheet metal to make it easier to form.



## 6.0. Acknowledgement

I owe a deep and sincere gratitude to my supervisor, Dr. Oliver Silumbe for his continuous and constructive guidance. His valuable suggestions and generous guidance enriched this study. I wish also to express my gratitude to Technical and Vocational Teachers' College (TVTC) for according me chance to carry out my research and produce the product from the college's workshops.

I will be insincere if I do not recognize contributions made by the following people; Mr. Kawana Makumbu (TVTC machinist) for tips on welding and milling; Mr. Mhango Mabvuto (HoD - Chizongwe Technical Secondary School-Chipata) for providing tips on drilling and machining on lathe and use of angle grinder; Mr. Chiyangi Jackson for paint tinting and spraying and Mr. Chishimba, B (Melt Cast – Kitwe) for providing free transport from his business place south-west of Kitwe to heavy industrial area, north of Kitwe in search for a company that could cast the moulds.

Special gratitude goes to my wife Catherine, and my grandsons Emmanuel, Ryan and Joshua for the patience when I worked long hours and away from them both during working days and weekends. To you all, I say, I love you.

## 7.0. References

[s Muzamil Hamiddin.pdf](#)

Accessed on 24/08/16

- [1] Ashby, M. F. and Jones, D. R. H. (2007) *Engineering Materials Part 1, 2, and 3*. Oxford: Pergamum Press<sup>[7]</sup>
- [2] Cannon, W. A. (1986). *How to Cast Small Metal and Rubber Parts*. (2<sup>nd</sup> Ed.,) New York: McGraw-Hill. Inc.
- [3] Carr, K. E. (2016). Levers Available online <http://quatr.us/physics/machines/lever2.htm> Accessed on 22/07/16
- [4] Chiang T.C. (2007). *Design and Simulation of Die and Punch for Sheet Metal on Round Bending* Available Online  
a. [http://umpir.ump.edu.my/2343/1/TEH\\_SOON\\_CHIANG.PDF](http://umpir.ump.edu.my/2343/1/TEH_SOON_CHIANG.PDF)
- [5] CSO (2007). *Environment Statistics in Zambia: Energy Statistics*. Lusaka: CSO Available Online  
a. [www.zamstats.gov.zm/report/Agric/Energy%20Statistics%20Publication.pdf](http://www.zamstats.gov.zm/report/Agric/Energy%20Statistics%20Publication.pdf)
- [6] Garratt, J. (1991). *Design and Technology*. Cambridge: Cambridge University Press.
- [7] Giudice, F., La Rosa, G. and Risitano, A. (2004). *Materials & Design- Materials selection in the Life-Cycle Design Process: A Method to Integrate Mechanical and Environmental Performances in Optimal Choice*. Catania: University of Catania
- [8] Hamiddin, A. M. B. (2009). *Design and Fabrication of Multipurpose Container*. University Malaysia Pahang  
a. Available Online <http://umpir.ump.edu.my/992/1/Ana>
- [9] Prabhakar, A., Haneef, M. and Ahmed, S. R. M. (2013). *Sheet Metal Forming Analyzes with Spring-back Deformation on U-Bends in Isotropic Plates*. Vol.2, Issue 9. Ramnagar; Ghousia College of Engineering
- [10] Sackey, J.K.N. & Amoakobene, S.K. (1996). *Metalwork Technology - The Motivate Series*. London: Macmillan Publishers Ltd.
- [11] Serway – College physics. 7<sup>th</sup> Edition.
- [12] Shah, Y. (2013). *Evaluation History of Power Press for Its Significant Placement in Present Machine Tool Industry* Available online
- [13] <http://machinetools.bhavyamachinetools.com/evaluation-history-of-power-press-for-its-significant-placement-in-present-machine-tool-industry-2/>  
a. Accessed on 19/07/16
- [14] Sharad, G. & Nandedkar, V. M. (nd). *Springback in Sheet Metal Bending - A Review*. IOSR Journal of Mechanical and Civil Engineering. ISSN 2278-1684 PP: 53-56 Available online [www.iosrjournals.org](http://www.iosrjournals.org)  
1. Accessed on 03/07/16
- [15] Smith, D. A. (2005). *Mechanical Press Types and Nomenclature*. Michigan: Available online <http://www.smithassoc.com/mechanical-press-types-andnomenclature/pix/C02.pdf>  
1. Accessed on 21/07/16

- [16] Yoshida, T., Isogai, E., Sato, K. & Hashimoto, K. (2013). *Springback Problems in Forming of High Strength Steel sheets and Countermeasures*. NIPPON Steel Technical Report No 103.
- [17] Walke, J .R. and Wilcox, G. (1970). *Modern Metalworking- Materials, Tools and Procedures*. Illinois: The Good heart - Wilcox Company Inc.
- [18] Zangwill, W.I. & Kantor, P.B. (1998). *Toward a Theory of Continuous Improvement and the Learning Curve*. (Abstract) Available Online <http://pubsonline.informs.org/doi/abs/10.1287/mnsc.44.7.910>  
Accessed on 14/09/16

## 8.0. Tables and Figures

The product

Orthographic projection views

