

# A Grid-Tied PV System for Commercial Load and Peak Load Reduction: South African Case Study

(Conference ID: CFP/470/2017)

Mamahloko Senatla \*, Henerica Tazvinga\*, Enos Moholisa and Crescent Mushwana

Energy Centre, Council for Scientific and Industrial Research, P.O. Box 395, Pretoria 0001, South Africa

{htazvinga,msenatla}@csir.co.za

## Abstract

Photovoltaic (PV) systems are increasingly being installed globally for various reasons including reducing the carbon footprint, improving energy access, for supply and demand side management purposes. The price of PV has been going down in recent years and the trend is expected to continue in future making this clean technology more attractive economically. In this paper a single axis tracking PV system connected to the grid is presented. Data measured over a period of year is used in the analysis with the objective of reducing both the load demand and peak load for a South African commercial entity. The results show load and peak load reductions of 3.4% and 4.5 % respectively. This shows that if such or similar systems are adopted by commercial entities on a larger scale there will be significant load and peak load reductions thereby reducing the energy bills.

**Keywords:** Load demand, peak load reduction, demand response, demand side management, energy savings

## 1 Introduction

Electricity peak demand is an important issue of concern by utility globally. Peak loads last for short periods of time making it very expensive for utilities to invest in and maintain the additional generation capacity to cater for a few peak hours in a day resulting in very small capacity utilization factors for the power plants. For this reason, most utilities charge an extra fee called a demand charge or demand penalty for high power usage consumers. Demand is calculated over a short time frame, usually 15 minutes, during which overall usage is tracked and averaged. One of the demand side management strategies used by consumers to reduce penalties is peak shaving. This refers to the ability to control grid electricity usage during periods of high demand in order to reduce demand penalties for the billing period. Utilities use Time of Use (TOU) tariff structures to encourage customers to shift electricity usage to periods when the charges are low. The high tariff charged during peak periods is aimed at reducing the peak demand by penalising customers who use electricity during this period.. While some studies have shown that battery storage charged during off-peak periods could be useful in reducing peak demand [1], battery life if cycled every day, efficiency and cost may limit their use. Also the TOU charges may not be high enough to justify the added expense of adding battery storage.

Most of the research work in various research communities analyses financial benefits for residential customers as opposed to commercial and industrial customers [2] [3]. For instance, the usage pattern of residential customers, collected from a pilot project in India is modelled and analysed for scaling the potential of DSM strategies with the results showing that there is a definite scope for load balancing as well as financial savings [3]. The paper does not include PV usage. With the current reduction in PV technology prices, grid-tied solar systems can effectively help reduce peak demand if the load is shifted to the period when PV power is generated. Grid-tied PV technology applications have been implemented globally owing to their market potentials and financial benefits. Demand charge management and TOU energy cost management are examples of such applications. Utilities generally price electricity and charge consumers based on total energy consumption (\$/kWh) and demand consumption (\$/kW), whereby end users such municipalities, industries and commercial entities pay for their peak demand on the grid. With commercial buildings electricity usage is high during the day and this coincides with the PV generation period without the need of any storage systems which can make such system more expensive. While grid-tied systems with storage have been studied in various literatures [4], they are not as economic as those without owing to the additional cost of storage even in cases where the batteries are charged by the renewable energy source. Optimization results of a grid –tied PV system with are presented in [5] to address self-consumption and degree of self-sufficiency for a supermarket in Aachen, Germany. The results show considerable savings which increased when storage of varying sizes were added assuming reduction in battery storage prices to a certain threshold.

A model for coordinated control of building end-use loads including cooling, lighting and plug loads, together with PV and ice storage integrated with packaged air conditioning units

is presented in his to analyse the impacts of these loads on peak demand and energy consumption in [6] a simulated medium-sized office building located in Virginia/Maryland, U.S. The results are used to enhance improved understanding of the contribution of demand response, solar PV and ice storage systems towards reducing building peak electricity demand and energy consumption while considering occupant thermal and lighting needs. A study that examines various energy efficiency approaches in commercial and institutional buildings is presented in [7], however it does not address peak load and load reduction opportunities as well as PV generation as a strategy for reducing these.

Focus of this paper is to analyse the impact of PV generation on the peak load and demand profile of a commercial entity while considering TOU energy pricing options offered by the local municipality. Distributed PV generation has great potential to reduce the load demand and energy bill of any consumer thereby reducing the load to be met by the utility herein referred to as the residual load. The main motivating factor for this paper is that load profiles of commercial buildings have a high correlation with the PV generation profile hence presenting a huge opportunity for economic savings. The remainder of the paper is structured as follows: Section 2 is the system architecture, Section 3 is the methodology, Section 4 the results and Section 5 is the conclusion.

## 2 System Architecture

Figure 1 shows a system of a grid-tied solar PV power plant that has been implemented within the entity's network. It has an installed capacity of 558 kWp and it is to the connected entity's internal grid on the 11kV bus bar (BB). The high voltage (132kV) supplied from the External Grid is stepped down to 11kV by the 132/11kV transformer as shown in Figure 1. The PV plant has its own step up transformer T1, converting the 400 V power generated by the PV to 11 kV. In this way, the DC output from the inverter is stepped up by T1 to require grid voltage (11kV). The network also consists of a loads connected on 400V network. The system is designed in such a way that PV generated output is made use of during the day whenever it is available. The imbalance is met by the supply from the external grid.

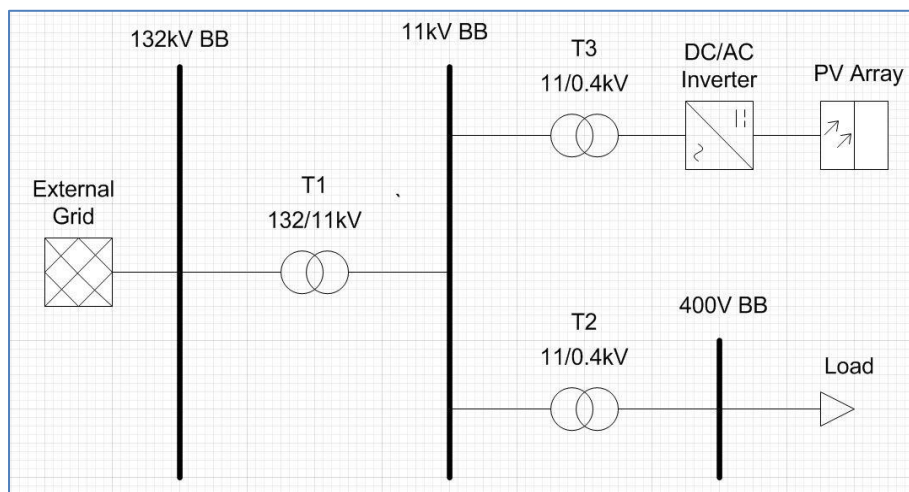

Figure 1: Grid-tied PV system

### 3 Methodology

The analysis is done using PLEXOS modelling software package. PLEXOS is a power systems modelling tool used for electricity market modelling and planning. PLEXOS applies mixed integer linear programming (MILP) to solve the unit commitment and economic dispatch problem (unit commitment and economic dispatch are solved simultaneously). The time of use tariff was used to calculate the cost of buying power from the municipality. The tariff comes in the structure presented in Table 1 and is applied at different times during the day as shown in Figure 2.

Table 1: Tariff structure from the municipality

TARIFF	DESCRIPTION	UNITS	RATE[R]
Fixed Charge		1.0000 month	R1581
Demand Charge	1.000pf 2016-12-09 11:30	6,320.0000 kVA	R104
Standard kWh - Low Season	Diversified; Billing Register End Reading 77660800.049kWh	925,956.0221 kWh	R0.7035
Peak kWh - Low Season	Diversified; Billing Register End Reading 77660800.049kWh	342,782.9834 kWh	R1.145
Off-Peak kWh - Low Season	Diversified; Billing Register End Reading 77660800.049kWh	1,060,220.9945 kWh	R0.501

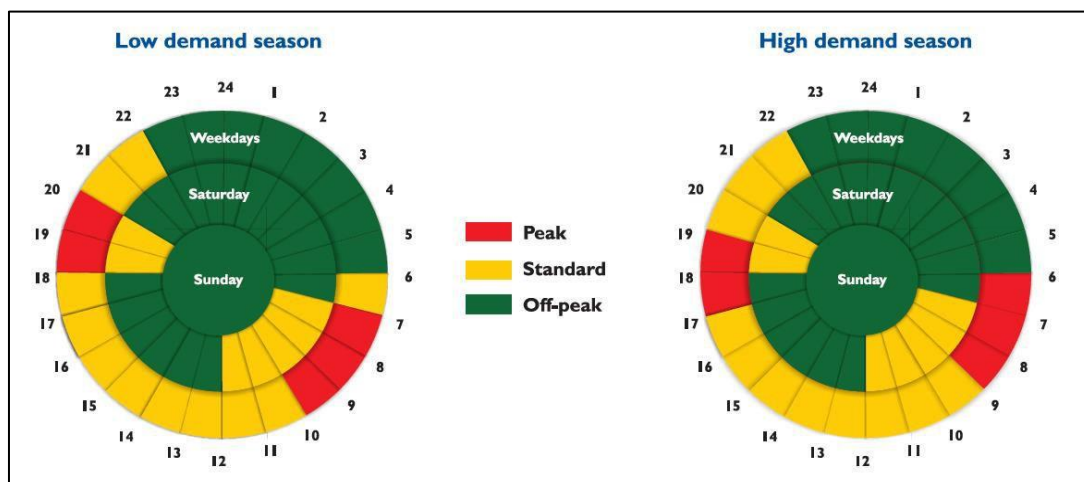

Figure 2: Hours for Megaflex tariff [9]

To conduct dispatch analysis, the tariff structure from the municipality must be converted to energy charge as in the case of standard, peak and off peak tariffs. This means that the demand charge must be changed to an energy charge using Equations [1] and [2].

$$MFT_{Wh} = \frac{MFT_0 + \text{energy charge}_w}{\text{peak power demand}} \quad [1]$$

$$MFT_{Wh} = \frac{MFT_0 + \text{energy charge}_0}{\text{peak power demand}} \quad [2]$$

, where  $MFT_0$  and  $MFT_w$  are the time of use tariffs from the municipality for both summer and winter months.  $\text{energy charge}_w$  is monthly electricity from the municipality.  $Q_a$  is the network demand charge, which is the cost of utilizing the network.  $\text{energy charge}_0$  and  $\text{energy charge}_w$  are energy tariffs for summer and winter respectively. The monthly peak power demand supplied by the municipality is used to calculate the total network demand cost. The total network charge is divided by the energy over the entire month to convert the energy charge to R/MWh. Since the TOU tariff is different for summer and winter months, this conversion is done for the two seasons. After the conversion, the tariff is as presented in Figure 3.

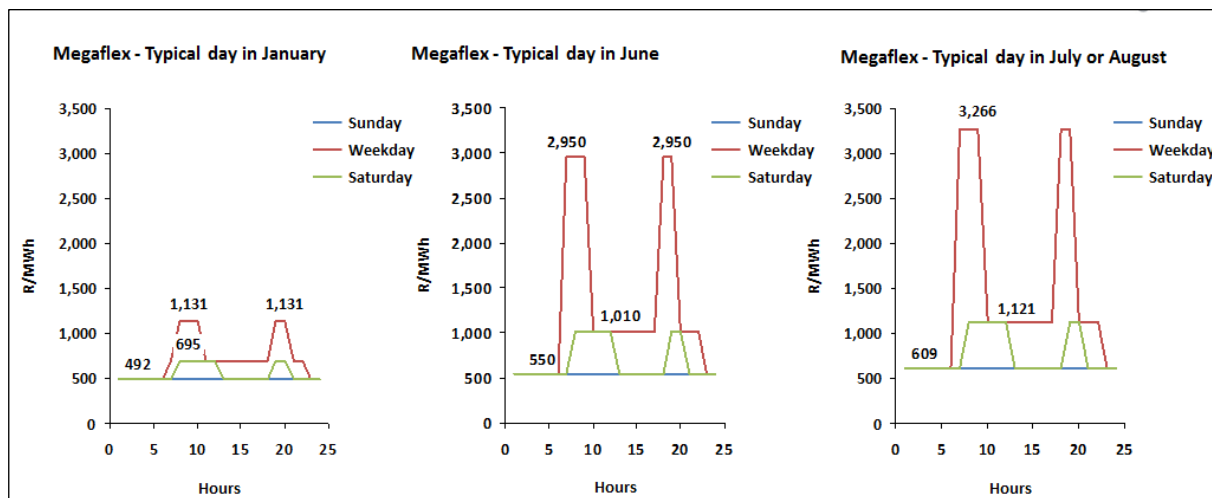

**Figure 3: Modelled tariff**

The total cost of dispatch within PLEXOS is calculated using Equation [3].

□□□

$$T_{\text{cost}} = \sum_{t=1}^{T} ic_{ge} \times T_{ow} + PV_{c} \times PV_{ge} \quad [3]$$

, where  $T_{\text{cost}}$  is total cost of electricity consumed by the entity,  $ic_{ge}$  is the amount of electricity supplied by the municipality,  $PV_{c}$  is the annualised cost of getting power from the PV plant and  $PV_{ge}$  is the amount of electricity generated by the PV plant. The weekly input load is as shown in

Figure 4. Hourly values of both PV and load demand for the years 2016 are used in the analysis in this

paper. The municipality applied the peak demand charge as shown in Figure 5 to the commercial entity resulting in the total peak demand charges as shown in Figure 8.

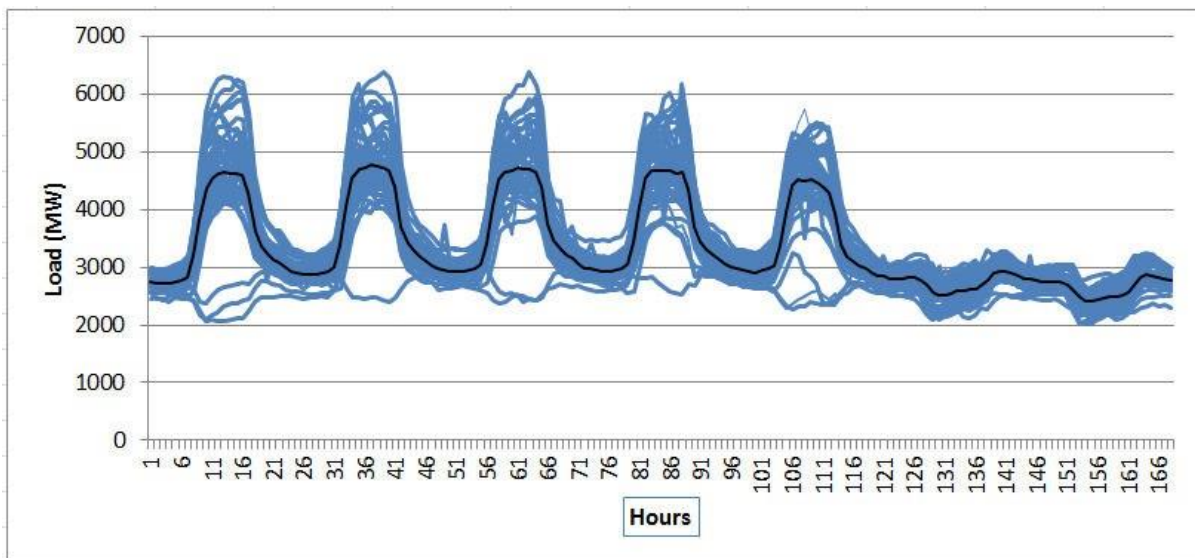

Figure 4: Weekly demand profile for the entity

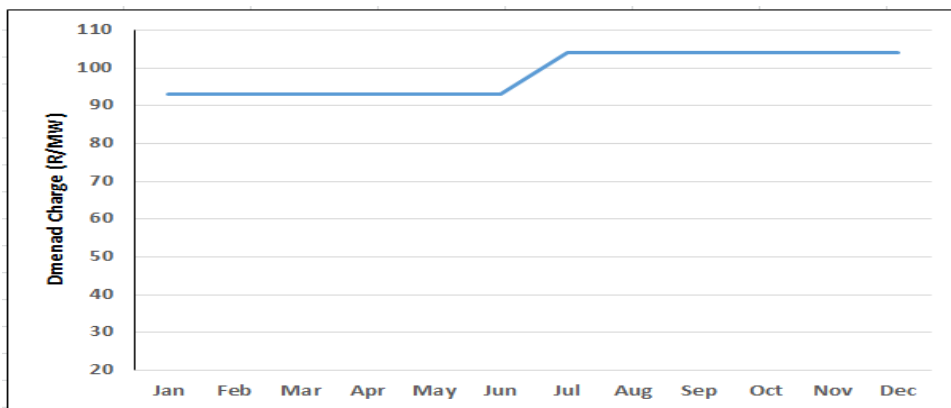

Figure 5: Demand charge from the municipality

## 4 Results

The monthly PV energy share ranges between 2.04% and 4.39 % owing the variable nature of the solar resource. It is clear from the figures shown that the PV output is lower in winter than in summer months. The lowest share value occurs in June while the highest share occurs in October and thereafter the figure goes slightly down. This is reasonable as this is the period when the rain season begins and the reduction is mainly due to cloud cover on most days. On average, the 558 kW<sub>p</sub> meets 3.42% of energy demand for the entity which is quite significant in terms of savings on the energy bill. Peak demand is reduced by 4.5% on average as shown in Table 2. Considering the size of the current PV system installed capacity, the monthly peak load reduction values are quite promising. Peak value for most commercial entities including the one presented in this paper, occur mostly during daytime. The load profiles presented in Figure 4 for the considered case study confirm that commercial buildings have a high correlation with the PV generation profile hence presenting a opportunities for economic savings. High reduction values are observed during summer months and in low values in winter months owing to the high energy demand during winter time as well as the fact that PV production is also low. In Figure 6 the fraction met by the PV is shown and this results in a change of the entity's demand profile.

**Table 2: Energy and peak demand contributions**

	1	2	3	4	5	6	7	8	9	10	11	12	Average
PV energy share (%)	3.94%	3.67%	3.42%	3.40%	2.68%	2.04%	2.69%	3.16%	3.60%	4.39%	3.82%	4.21%	<b>3.42%</b>
Peak load reduction (%)	3.20%	6.92%	3.13%	4.27%	5.65%	0.51%	0.76%	6.83%	5.11%	6.44%	6.14%	4.64%	<b>4.47%</b>

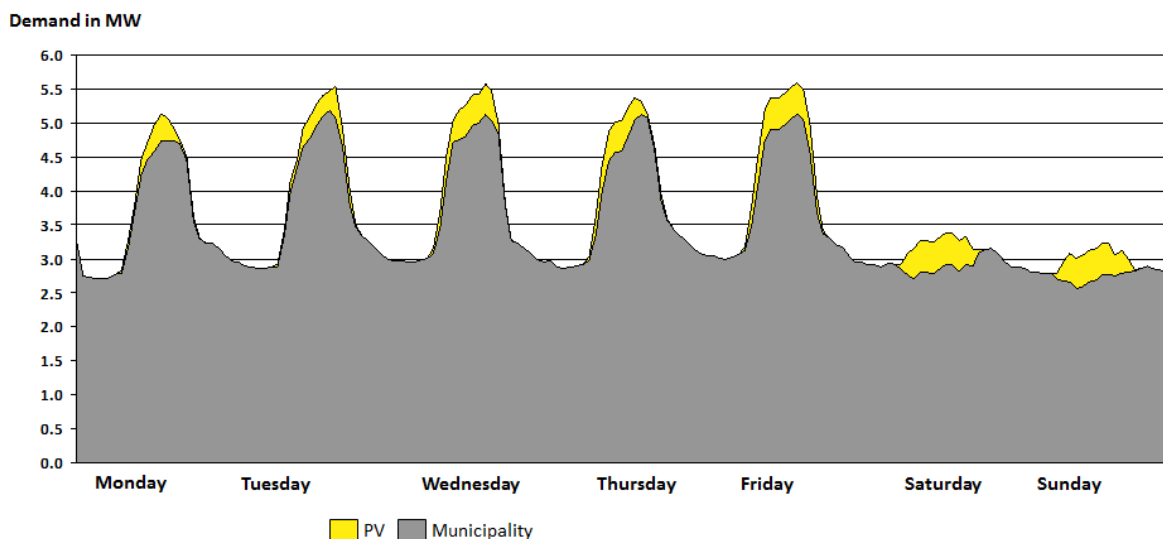

**Figure 6: Typical weekly demand**

The total energy demand for the study year is shown as 30 GWh and of his about 1 GWh is met by PV generation resulting in a net demand of 29 GWh. The total cost paid to the municipality is R22.6 million while the cost paid to generate electricity from PV is R1.8 million giving a total cost of R24.4.

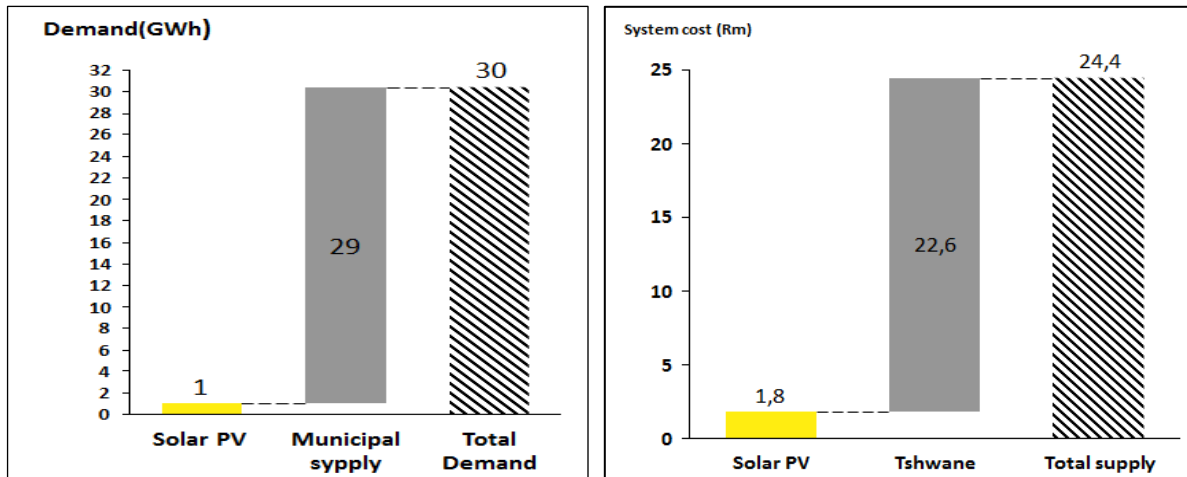

**Figure 7: Annual energy demand and total annual system cost**

The monthly peak demand values for the cases with and without the PV system contribution are shown in Figure 8. These values show the impact of the PV system contribution during the year under consideration. The greatest PV contribution occurs in summer when it is sunny.

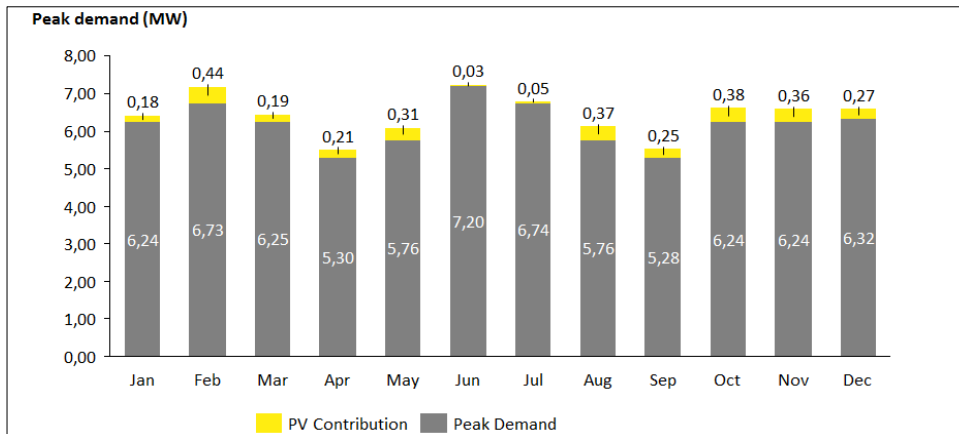

**Figure 8: Monthly peak demand with and without PV generation**

Figure 9 compares the demand charge reductions for two cases: monthly demand charge with no PV and with PV in 2016.

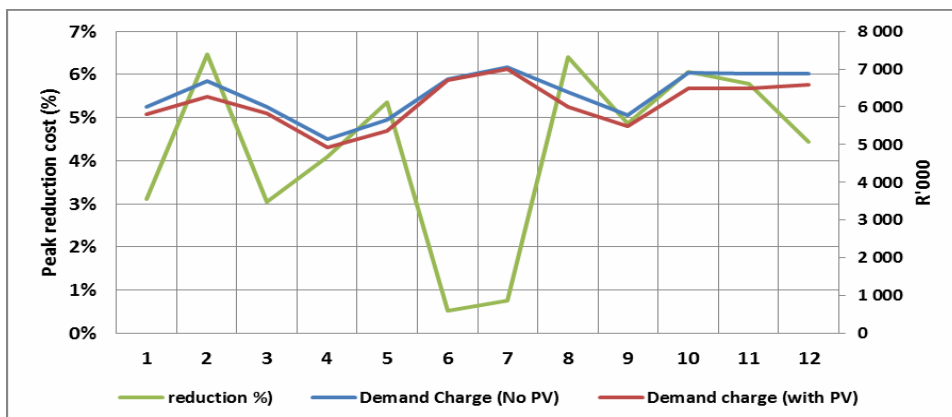

**Figure 9: Demand charge reduction cost**



The peak demand costs are shown to be higher in the case without PV than in the case with PV in all months of the year except for June and July where the difference is insignificant. The percentage cost reductions are shown in the same figure.

## 5 Conclusions

A grid connected single axis tracking PV system has been presented in this paper. The impact of PV generation on the peak load and demand profile of a commercial entity while considering TOU energy pricing options offered by the local municipality has been presented. To conduct dispatch analysis, the tariff structure from the municipality, a methodology for incorporating the demand charge into energy charges was developed was applied to standard, peak and off peak tariffs. The monthly load and peak load reductions reveal the trends during winter and summer seasons. The results show annual average load and peak load reductions of 3.4% and 4.5 % respectively. The results show that if similar systems are adopted by commercial entities on a larger scale there will be significant load and peak load reductions thereby reducing the energy bills. Future work will include performance analyses of the double axis and rooftop mounted PV systems as part of the commercial entity's move towards self-sufficiency.

## **REFERENCES**

- [1] N. E. M. Rozali, S. R. W. Alwi, Z. A. Manan and J. J. Klemeš, “ Peak-off-peak load shifting for hybrid power systems based on Power Pinch Analysis,” *Energy*, vol. 90, pp. 128-136, 2015.
- [2] Z. Wu, H. Tazvinga and X. Xia, “ Demand side management of photovoltaic-battery hybrid system,” *Applied Energy*, no. 148, pp. 294-304, 2015.
- [3] F. Yang and X. Xia, “ Techno-economic and environmental optimization of a household photovoltaic-battery hybrid power system within demand side management,” *Renewable Energy*, no. 108, pp. 132-143, 2017.
- [4] J. Thakur and B. Chakraborty, “Thakur, Jagruti; Chakraborty, Basab Demand side management in developing nations: A mitigating tool for energy imbalance and peak load management,” *Energy* , no. 114, pp. 895-912, 2016.
- [5] P. Si, Y. Feng, Y. Lv, X. Rong, Y. Pan, X. Liu and J. Yan, “ An optimization method applied to active solar energy systems for buildings in cold plateau areas–The case of Lhasa,” *Applied Energy*, no. 194, pp. 487-498, 2017.
- [6] G. Merei, J. Moshövel, D. Magnor and D. U. Sauer, “ Optimization of self-consumption and techno-economic analysis of PV-battery systems in commercial applications,” *Applied Energy*, no. 168, pp. 171-178, 2016.
- [7] F. Sehar, M. Pipattanasomporn and S. Rahman, “ An energy management model to study energy and peak power savings from PV and storage in demand responsive buildings,” *Applied Energy* , no. 173, pp. 406-417, 2016.
- [8] R. Ruparathna, K. Hewage and R. Sadiq, “ Improving the energy efficiency of the existing building stock: A critical review of commercial and institutional buildings,” *Renewable and Sustainable Energy Reviews*, no. 53, pp. 1032-1045, 2016.
- [9] Eskom, “Tariff and Charges Booklet 2016/2017,” Eskom, Johannesburg, 2016.